

T-ROTOR OIL PUMPS

Continuous to feeding
Supplying Fuel and Lubrication oil
Hydraulic composition





**ARYUNG takes
a leap forward
in the 21st century**
ARYUNGは21世紀に飛躍する

Since its founding in 1976, Aryung has developed with one goal of being a specialized oil pump company, and is striving to provide the best quality and reliability to customers in the 21st century.

1976年の創業以来、Aryungはオイルポンプの専門会社を目指して発展し、21世紀のお客様に最高の品質と信頼性を提供できるよう努めています。

**ARYUNG recognized
in the world**
ARYUNGは世界
で認められています

Based on world-class quality certifications such as CE, NRTL, and RoHS, ARYUNG currently exports to more than 23 countries, especially producing products under ISO-9001 and ISO-14001 quality management.

CE、NRTL、RoHSなどの世界クラスの品質認証に基づいて、ARYUNGは現在23カ国以上に輸出しています。特にISO-9001およびISO-14001の品質管理を通じて製品を製造しています。

**Focused Goals
Continuous research
and development**
目標を達成するために継続
的な研究開発

ARYUNG focuses on research and development, and in order to achieve the goal of quality improvement and best customer service, we are making every effort to manufacture through thorough quality control and inspection.

ARYUNGは研究と開発、品質向上と最高の顧客サービスを目標に、徹底した品質管理と検査を通じて私たちは製造にあらゆる努力をしています。

**Quality First, Thorough
Customer Satisfaction**
品質第一、
徹底した顧客満足

We aim to achieve the goal of customer satisfaction by continually tracking through thorough inspection and inspection.

徹底した検査を通じて継続的に追跡することにより、顧客満足の目標を達成することを目指しています。

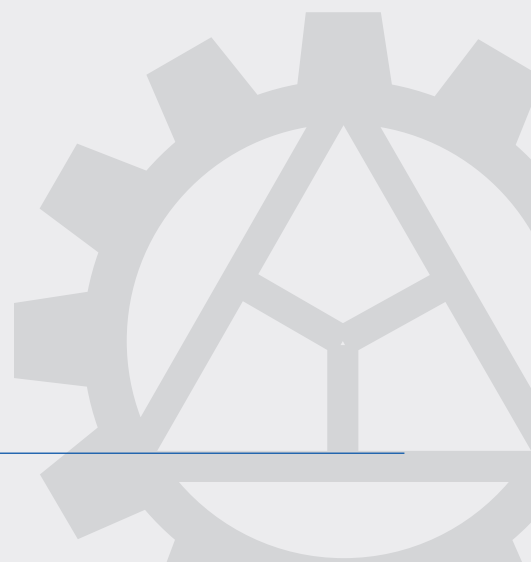

CONTENTS

www.aryung.co.kr

01 Technical data | 技術データ

Overview of the pump ポンプの概要	04
Precautions for use 使用上の注意	05
Cautions when selecting a motor モーター選択時の注意事項	06
System configuration example システム構成の例	07
Kinematic viscosity (cSt) change with temperature 温度によって動粘度(cSt) 変化	08

02 T-Rotor pumps | トロター ポンプ

AR1-F Series	09
AR2-FC Series	10
ATP-S Series	11
ATP-HA Series	12
ATP-H/HF Series	15
ATP-4** HVB Series	16

03 Motor T-Rotor pumps | モーター付きトロターポンプ

AMTP - MS / MT Series	17
AMTP - HA Series	20
AMTP - HAVBF Series	22
AMTP - HA/HAVB Series	24
AMTP - LN Series	26
AMTP - 320LNVB Series	28
AMTP - HFVB Series	29

04 Fan Cooler Unit

AFC - MSFVB Series	31
--------------------	----

05 Appendix | 附录

Failure cause and countermeasure 故障原因と対策	34
Wiring diagram 配線図	36
History 沿革	37

Overview of the pump

T-ROTOR refers to the trajectory of one point inside a circular plate that makes rolling contact motion around a fixed circle without slipping, and the trajectory formed by the outer rolling motion of the disk outside the circumference is called Epi-trochoid. The trajectory by the inner rolling motion is called Hypo-trochoid.

The T-Rotor Pump is a kind of internal gear pump composed of a pair of internal and external gears manufactured by this Trochoid Curve.

How it Works

The T-ROTOR pump is sucked by forming a certain space while a pair of teeth manufactured by the principle of Trochoid Curve perform inward rolling motion. It is a pump that discharges.

In-Rotor, which has one fewer gear teeth than Out-Rotor, rotates eccentrically by a certain distance from the external gear. As a pump designed to forcibly suck and discharge fluid in accordance with the repeated motion of a constant space is always formed between the external teeth and the space is continuously large and small, the motion of the rotor is as shown in the picture below.

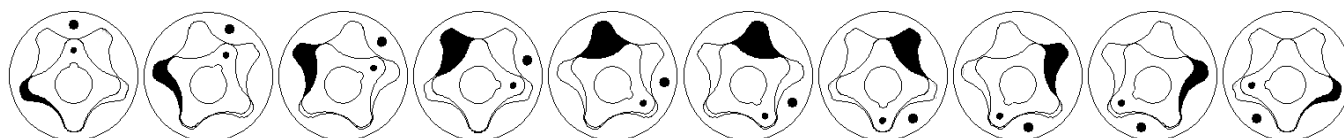

Features of the pump

1. High suction pressure and high mechanical and volumetric efficiency.
2. Since the internal and external gears make rolling contact motion by trochoid curve, the relative speed is smaller than that of the gear pump, so the tooth wear and discharge pulsation are less.
3. The simple structure makes it easy to disassemble, assemble, and repair. In addition, it is smaller than the gear pump of the same capacity, has a longer service life, and has more discharge per rotation.
4. Crescent-Shaped Spacer is not required like Gear Pump, and there are various uses such as lubrication, hydraulic, and transport.
5. Since it always makes a one-point contact motion, the rotation range is wide from low and high speed rotation (300~3000rpm).

ポンプの概要

T-ROTORとは、円板の内側の一点が滑らずに固定円の周りを転がり接触する軌道を指し、円周外の円盤の外側の転がり運動によって形成される軌道をエピトロコイドと呼びます。内側の転がり運動によって形成される軌道は、ハイポトロコイドと呼ばれます。

T-Rotorポンプは、このトロコイド曲線によって製造された1双の内歯車と外歯車で構成される一種の内歯車ポンプです。

使い方法

T-ROTORポンプは、トロコイド曲線の原理で製造された一对の歯が内向きの回転運動を行う間、特定の空間を形成することによって吸引され、排出するポンプです。

アウトローターよりもギアの歯が1つ少ないインローターは、外部ギアから一定の距離だけ偏心して回転します。外歯の間には常に一定の空間の繰り返し運動に応じて流体を強制的に吸入・排出するポンプが形成されており、その空間は連続的に大小を問わず、ローターの動きは下図のようになります。

ポンプの特徴

1. 高い吸引圧力と高い機械的および体積効率。
2. 内歯車と外歯車はトロコイド曲線により転がり接触運動をするため、ギアポンプよりも相対速度が遅く、歯の摩耗や吐出脈動が少なくなります。
3. シンプルな構造で分解・組立・修理が容易です。また、同容量のギアポンプよりも小型で、耐用年数が長く、1回転あたりの吐出量が多くなっています。
4. ギアポンプのように三日月形のスペーサーは不要で、潤滑、油圧、輸送などさまざまな用途があります。
5. 常に一点接触動作を行うため、低速回転から高速回転(300～3000rpm)までの回転範囲が広がります。

Notes on use

• Pump installation location

Pump installation location should be a location with good ventilation and low temperature and humidity, and the location of the pump should be slightly higher than the tank. It is good to install it in place.

• Discharge volume, viscosity, rotation speed

The pump discharge amount is proportional to the number of rotations, and the proper number of rotations is 1000-1800rpm, and the dynamic viscosity is in the range of 20~1000cSt at 40°C. Also, even for oil of the same standard, the kinematic viscosity varies depending on the temperature, so special attention should be paid to the selection of oil.

• Suction side piping

When piping on the suction side, completely seal it so that air does not enter, and reduce the use of elbows, valves, cocks, etc. Also, make sure that the suction side pipe is thick and short and the flow velocity at suction is 1.5m/sec or less.

• Suction side filter

Make sure to use a filter of 100 mesh or more on the suction side, the suction pressure should be 0~0.15kg/cm² or less, and the filtration area should be at least twice the pump discharge amount.

• Discharge side piping

The discharge side piping should have a flow velocity of 3m/sec or less. If the piping diameter is small and the flow velocity is high, the pump is loaded more than necessary, the flow rate decreases, and the oil temperature rises.

• Oil Tank

Make sure that the oil tank's capacity is at least 3 times the pump's discharge per minute, and an oil gauge must be attached.

If the tank capacity is too small, the oil temperature rises, deterioration is rapid, and it may cause poor suction.

In addition, keep the distance between the suction filter and the drain pipe as far as possible, and install two or more diaphragms in the tank to prevent air bubbles and foreign substances from entering.

• Flow rate calculation

Suction speed less than 1.5m/sec

Discharge speed less than 3m/sec

$$V = 4Q / \pi d^2$$

V: flow velocity (m/sec)

Q: Flow rate (m³/sec)

d: inner diameter of pipe (m)

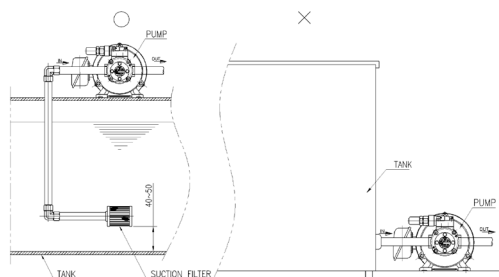

使用上の注意

• ポンプの設置場所

ポンプの設置場所は、換気が良く、温度と湿度が低い場所である必要があり、ポンプの場所はタンクよりわずかに高い場所である必要があります。所定の位置に取り付けるとよいでしょう。

• 吐出量、粘度、回転数

ポンプ吐出量は回転数に比例し、適正回転数は1000~1800rpm、動粘度は40°Cで20~1000cStの範囲です。また、同規格のオイルでも動粘度は温度によって変化するため、オイルの選定には特に注意が必要です。

• 吸込側配管

吸込側配管の場合は、空気が入らないように完全に密閉し、エルボ、バルブ、コック等の使用を減らしてください。また、吸込側配管は太くて短く、吸込時の流速を確認してください。1.5m/秒以下です。

• サクションサイドフィルター

吸込側は必ず100メッシュ以上のフィルタを使用し、吸込圧力は0~0.15kg/cm²以下、ろ過面積はポンプ吐出量の2倍以上にしてください。

• 排出側配管

吐出側配管の流速は3m/秒以下である必要があります。配管径が小さく流速が速いと、ポンプに必要以上の負荷がかかり、流量が減少し、油温が上昇します。

• オイルタンク

オイルタンクの容量が毎分ポンプの吐出量の3倍以上であることを確認し、オイルゲージを取り付ける必要があります。

タンク容量が小さすぎると油温が上昇し、劣化が早く、吸引不良の原因となります。

また、吸込フィルターとドレンパイプの距離をできるだけ離し、気泡や異物の侵入を防ぐため、タンク内にダイヤフラムを2つ以上取り付けてください。

• 流量計算

吸引速度が1.5m/秒未満

放電速度が3m/秒未満

$$V = 4Q / \pi d^2$$

V: 流速 (m / sec)

Q: 流量 (m³/秒)

d: パイプの内径 (m)

Cautions when selecting a motor

As the discharge volume or pressure of the pump increases, the power consumption of the motor increases. For the same type of oil, as the temperature decreases, the viscosity increases and the power consumption of the motor increases (25° to 40° standard).

Motors produced by our company are high-efficiency (750W or more) motors under the implementation of the lowest consumption efficiency system. The rated voltage of the standard product is 220V / 380V, and other specifications are order specifications. Electrical specifications and appearance are subject to change.

・ Calculation of required power

Because the power required for the pump is changed by the dynamic viscosity and temperature of the oil in addition to the shaft power of the pump (considering seasonal influences), calculate the power required based on the worst case.

・ Power required calculation formula (axis power)

$$Lm = (P \cdot Q) / (612 \cdot H) \text{ (KW)}$$

$$Lm = (P \cdot Q) / (450 \cdot H) \text{ (HP)}$$

P: discharge pressure (kg/cm²)

Q: Discharge amount (ℓ/min)

η: coefficient (maximum pump efficiency)

Discharge Pressure (kg/cm ²)	Coefficient (η)	Discharge Pressure (kg/cm ²)	Coefficient (η)
0 ~ 3	0.2 ~ 0.25	8 ~ 10	0.35 ~ 0.45
3 ~ 5	0.25 ~ 0.3	10 ~ 20	0.45 ~ 0.55
5 ~ 8	0.3 ~ 0.35	20 ~	0.55 ~ 0.65

Notes on operation

When starting the pump, be sure to check the direction of rotation. If it rotates in the reverse direction, the oil-seal is damaged and the pump cannot be used. Refer to the rotation direction indicator sticker or embossed marking on the pump.

Before operation, operate after injecting oil into the discharge side to form an oil film. If the pump is operated while the oil is dried in the pump while it is being transported or left unattended for a long time, there is a risk of poor suction, noise and damage to the pump. If the oil is not sucked and idle, the oil-seal may be damaged.

Vibration from the pump. If an abnormal sound occurs, the operation should be stopped immediately, and the following inspection items should be taken to correct the problem before driving.

- Damage during transportation, looseness in tightness, etc.
- Appropriateness of tank oil level
- Sealing condition of suction pipe
- Kinematic viscosity of the fluid used

If the pressure is set too high, overload, vibration and noise of the motor will be generated. Therefore, the proper pressure must be set.

モーター選択時の注意事項

ポンプの吐出量または圧力が増加すると、モーターの消費電力が増加します。

同じ種類のオイルの場合、温度が下がると粘度が上がります。

モーターの消費電力が増えます(標準で25°から40°)。

当社製モーターは、消費効率が高效率システムを採用した高效率(750W以上)のモーターです。標準品の定格電圧は220V / 380Vで、その他の仕様は注文仕様です。電気的仕様および外観は変更される場合があります。

・ 必要な電力の計算

ポンプに必要な出力は、ポンプのシャフト出力に加えて、オイルの動的粘度と温度によって変化するため(季節的な影響を考慮)、最悪の場合に基づいて必要な出力を計算します。

・ 必要な電力計算式(軸電力)

$$Lm = (P \cdot Q) / (612 \cdot H) \text{ (KW)}$$

$$Lm = (P \cdot Q) / (450 \cdot H) \text{ (HP)}$$

P: 吐出圧力 (kg/cm²)

Q: 排出量 (ℓ/分)

η: 係数(最大ポンプ効率)

操作上の注意

ポンプを始動するときは、必ず回転方向を確認してください。逆回転するとオイルシールが破損し、ポンプが使用できなくなります。ポンプの回転方向表示シールまたはエンボスマークを参照してください。

運転前は、吐出側にオイルを注入して油膜を形成してから運転してください。輸送中や長時間放置した状態でポンプ内の油を乾燥させた状態でポンプを運転すると、吸引不良、異音、ポンプの損傷の恐れがあります。オイルが吸引されてアイドル状態になっていないと、オイルシールが損傷する可能性があります。

ポンプからの振動。異音が発生した場合は、直ちに運転を停止し、以下の点検項目で問題を修正してから運転してください。

- 輸送中の損傷、締まりの緩みなど。
- タンクオイルレベルの適切性
- サクションパイプのシール状態
- 使用する流体の動粘度

圧力を高く設定しすぎると、モーターの過負荷、振動、騒音が発生します。したがって、適切な圧力を設定する必要があります。

System configuration example | システム構成例

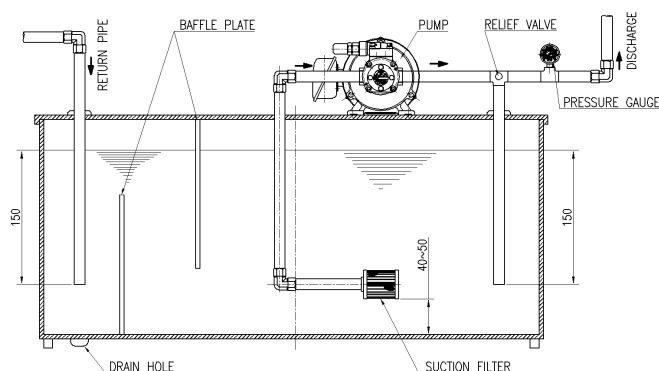

ATP-HAVB exploded view | ATP-HAVB分解図

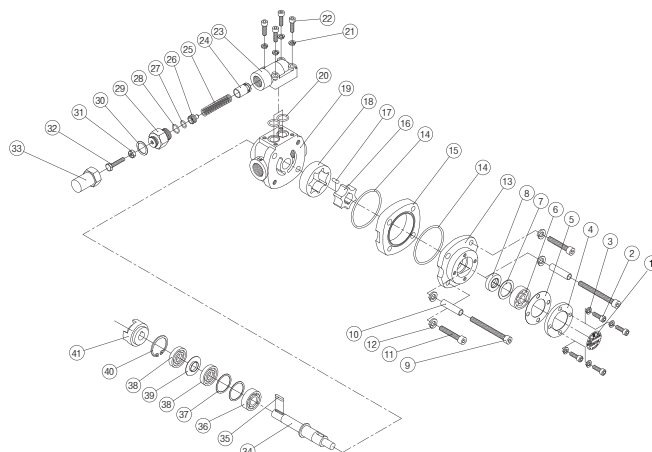

Relief valve control method | リリーフバルブ制御方式

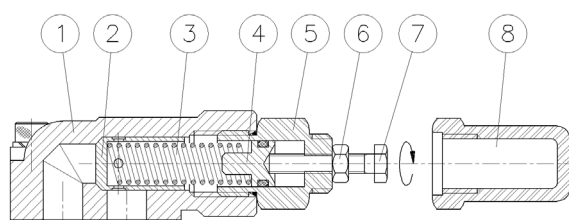

- ① Relief valve body ④ Spring seat ⑦ Adjust bolt
- ② Piston ⑤ Plug bolt ⑧ Cap nut
- ③ Spring ⑥ Lock nut

1. Open the ⑧ cap nut of the relief valve and turn the ⑦ hex adjust bolt to the right to increase the pressure.
2. Turning the ⑦ hex adjust bolt to the left decreases the pressure.
3. After pressure control is over, tighten the ⑥ lock nut and close the ⑧ cap nut.

1. リリーフバルブの⑧袋ナットを開き、⑦六角調整ボルトを右に回して圧力を上げます。
2. ⑦六角アジャストボルトを左に回すと、圧力が下がります。
3. 圧力制御が終了したら、⑥個のロックナットを締め、⑧個のキャップナットを閉じます。

Pressure setting range | 圧力設定範囲

Spring classification	Pressure range 圧力範囲 MPa
1S	0 ~ 0.4
2S	0.4 ~ 0.8
3S	0.6 ~ 1.5
4S	1.2 ~ 3.0

NO.	PART NAME	NO.	PART NAME
1	Name Plate	21	Spring Washer
2	Wrench Bolt	22	Wrench Bolt
3	Spring Washer	23	Relief V/V Body
4	Bearing Cover	24	Piston
5	Packing	25	Spring
6	Ball Bearing	26	Spring Seat
7	Spacer Collar	27	O-ring
8	Oil Seal	28	O-ring
9	Wrench Bolt	29	Plug Bolt
10	Sus Pipe	30	Packing
11	Wrench Bolt	31	Lock Nut
12	Spring Washer	32	Adjust Bolt
13	Pump Cover	33	Cap Nut
14	O-ring	34	Shaft
15	Pump Body	35	Key
16	In Rotor	36	Ball Bearing
17	Round Key	37	Spacer Collar
18	Out Rotor	38	Oil Seal
19	Port Housing	39	Back Up Ring
20	O-ring	40	Snap Ring
		41	Pump Coupling

Changes in kinematic viscosity (cSt) according to temperature | 温度による動粘度 (cSt) の変化

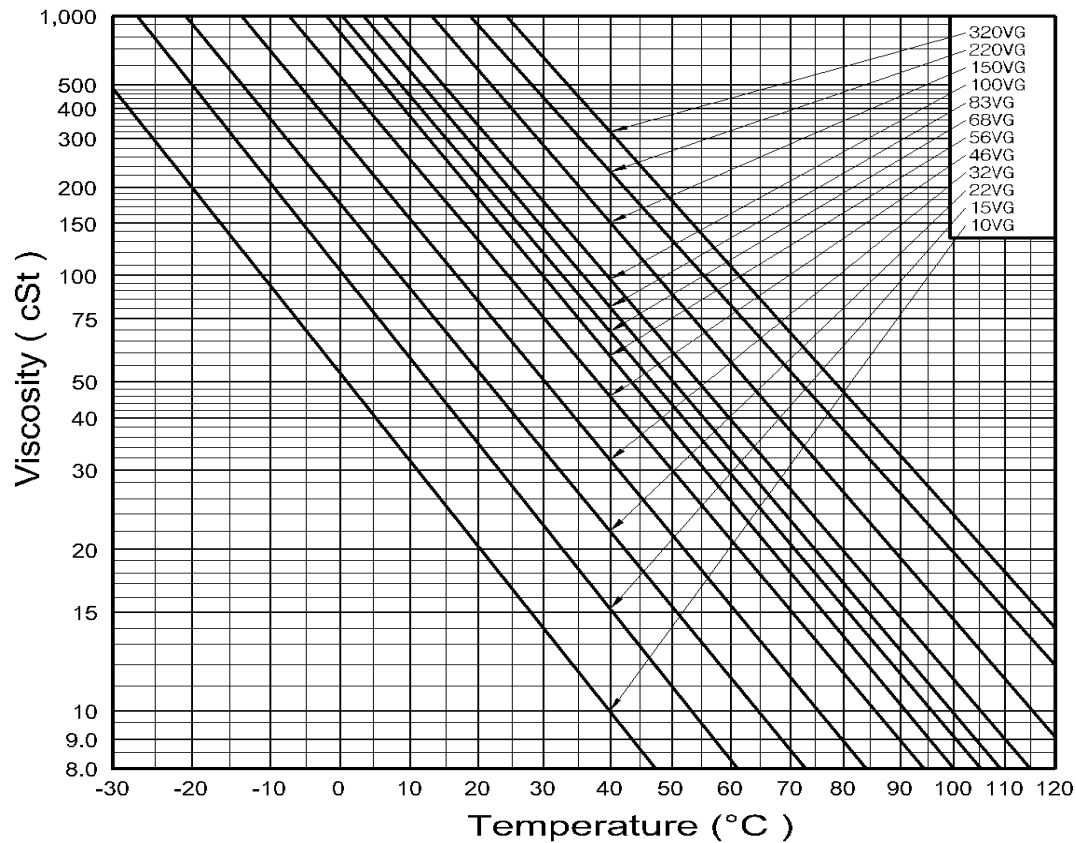

Temp erature (°C)	VG2	VG3	VG5	VG7	VG10	VG15	VG22	VG32	VG46	VG68	VG100	VG150	VG220	VG320	VG460
-20	-	-	-	-	-	-	-	1170	3600	8000	-	-	-	-	-
-10	-	-	-	-	-	-	-	440	1270	2500	4500	-	-	-	-
0	4 (1°C)	10 (1°C)	17 (1°C)	32 (1°C)	52 (1°C)	109 (1°C)	169 (1°C)	240	520	950	1600	3570	5329	8990	15350
10	4	7	12	20	32	62	93	135	261	433	772	1237	1996	3211	5200
20	3	5	9	14	20	36	53	76	134	212	356	553	861	1328	2050
30	3	4	6	9	14	23	33	46	76	115	184	277	417	620	920
40	2	3	5	7	10	15	22	32	46	68	100	150	220	320	460
50	2	3	4	5	7	11	15	21	30	43	63	91	129	180	250
60	2	2	3	4	6	8	11	15	21	29	41	57	80	108	146
70	1	2	2	3	4	6	8	11	15	20	28	39	52	70	92
80	1	2	2	3	4	5	7	9	11	15	20	27	36	47	60
90	1	1	2	2	3	4	5	7	9	11	15	20	26	33	42
100	1	1	2	2	2.6	3.4	4.3	5.3	6.7	8.5	11.1	14.5	18.7	24	30.2
110	-	-	1	2	2	3	4	5	6	7	9	12	15	18	23
120	-	-	-	1	2	2	3	4	5	6	7	9	12	14	17

※ This data is a reference material to help users understand, and characteristics may differ depending on each oil manufacturer.

※ このデータはユーザーの理解に役立つ参考資料であり、オイルメーカーごとに特性が異なる場合があります。



ARI - 3F

① ②

- ① ARYUNG T-Rotor Pump
- ② Pump classification / ポンプ分類

- AR1-F type is a reversible pump in which suction and discharge directions are always constant regardless of the direction of rotation of the pump.
- The main use is suitable for supplying lubrication to machine tools, industrial machines, and other general-purpose machines.
- AR1-Fタイプは、ポンプの回転方向に関係なく、吸込方向と吐出方向が常に一定であるリバーシブルポンプです。
- 主な用途は、工作機械、産業機械、その他の汎用機械に潤滑油を供給するのに適しています。

Type	Per rotation (cm ³ /rev)	Discharge flow (ℓ/min)		Allowable pressure (MPa)	Allowable rotation speed (rpm)	Weight (Kg)
		1000rpm	1800rpm			
AR1-2F	2.0	2.0	3.6	0.5	500 ~ 2000	1.2
AR1-3F	2.5	2.5	4.5	0.5	500 ~ 2000	1.3

Appearance | 外観

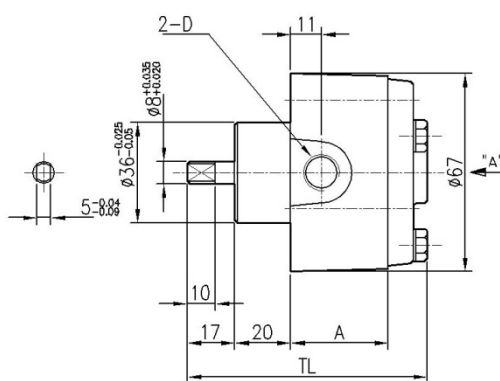
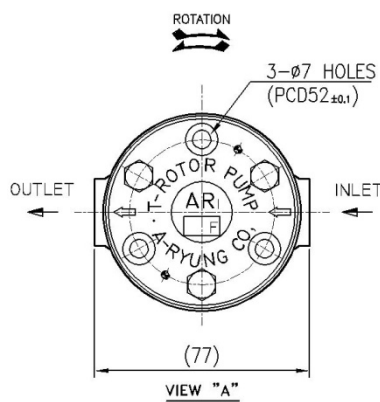

Type	A	TL	D (Port Dia)	
			INLET	OUTLET
AR1-2F	32	83	PT 1/4"	PT 1/4"
AR1-3F	35	86	PT 1/4"	PT 1/4"

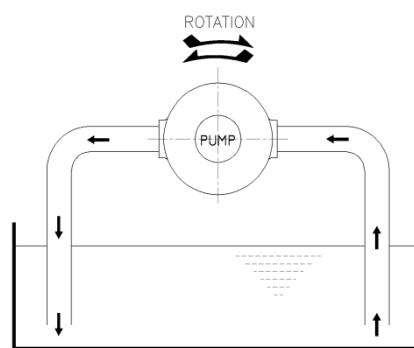

Intake and discharge ports by rotation direction
回転方向による吸気ポートと排出ポート

Application | 適用

- Fluid: Oils
- Kinematic viscosity (at 40°C)
: 20 ~ 220 cSt
- Operating temperature
: 80°C Below

Material | 材質

- Pump body : Cast iron
- Pump cover : Cast iron
- Shaft : Steel
- Rotor : Powder steel
- Oil-seal : NBR (ø8×ø18×7t)



AR2 - 4FC

① ②

① ARYUNG T-Rotor Pump
② Pump classification / ポンプ分類

- AR2-FC type is a reversible pump in which suction and discharge directions are always constant regardless of the direction of rotation of the pump.
- The main use is suitable for supplying lubrication to reducers, refrigerators, compressors, railway vehicles, ship engines and machine tools.
- AR2-FCタイプは、ポンプの回転方向に関係なく、吸込方向と吐出方向が常に一定であるリバーシブルポンプです。
- 主な用途は、減速機、冷蔵庫、コンプレッサー、鉄道車両、船舶エンジン、工作機械に潤滑油を供給するのに適しています。

Type	Perotation (cm ³ /rev)	Discharge flow (ℓ/min)		Allowable pressure (MPa)	Allowable rotation speed (rpm)	Weight (Kg)
		1000rpm	1800rpm			
AR2-4FC	4	4	7.2	0.5	500 ~ 2000	4.6
AR2-8FC	8	8	14.4	0.5	500 ~ 2000	4.9
AR2-12FC	12	12	21.6	0.5	500 ~ 2000	5.2

Appearance | 外観

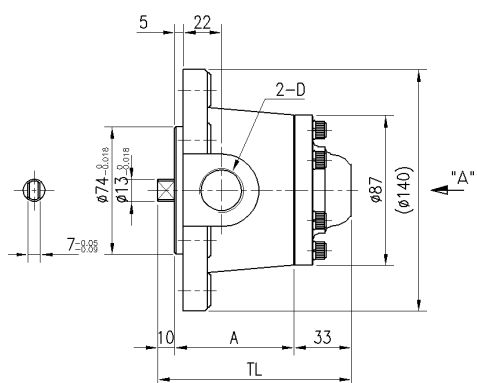
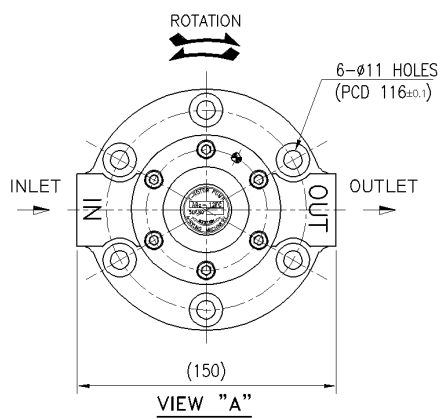

Type	A	TL	D (Port Dia)	
			INLET	OUTLET
AR2-4FC	49	92	PT 1/2"	PT 3/8"
AR2-8FC	59	102	PT 3/4"	PT 1/2"
AR2-12FC	69	112	PT 3/4"	PT 3/4"

Application | 適用

- Fluid: Oils
- Kinematic viscosity (at 40°C) : 20 ~ 220 cSt
- Operating temperature : 80°C Below

Material | 材質

- Pump body : Cast iron
- Pump cover : Cast iron
- Shaft : Steel
- Rotor : Powder steel
- Oil-seal : NBR (Ø13×Ø30×8t)

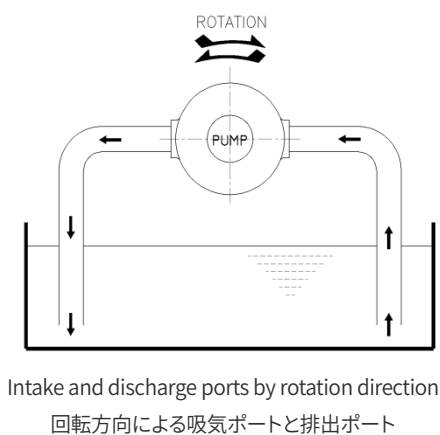



ATP - 11 S VB

- ① ② ③ ④

- ① ARYUNG T-Rotor Pump
- ② Pump classification / ポンプ分類
- ③ Shaft shape / シャフト形状
MS: Section cutting / 断面カット
S: Double-sided cutting / 両面カット
- ④ Relief Valve / リリーフ弁
VB: mounting / 装着
No mark: none / なし

- ATP-S type is a small gear pump and is mainly used for supplying lubrication to various machine tools, industrial machines, and agricultural machines.
- This pump rotates constantly in only one direction specified and can be operated in combination with the power of the machine or the motor.
- It is easy to adjust pressure as it has its own relief. (Option)
- ATP-S タイプは小型ギアポンプで、主に各種工作機械、産業機械、農業機械に潤滑油を供給するために使用されます。
- このポンプは、指定された一方方向にのみ常に回転し、機械またはモーターの動力と組み合わせて操作できます。
- 独自のリリーフがあるため、圧力調整が簡単です。(オプション)

Appearance | 外観

ATP-S

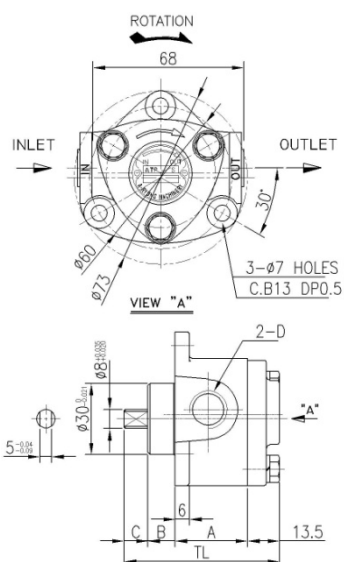

ATP-SVB

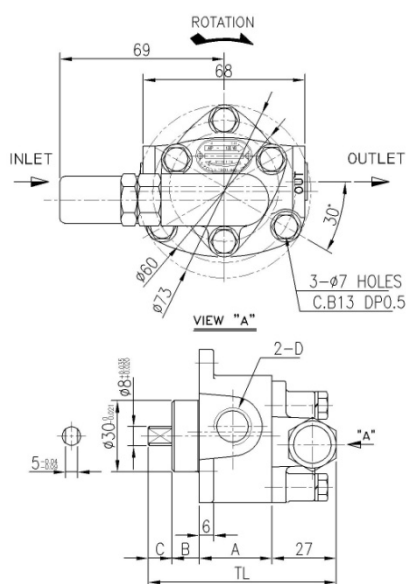

Type	Perotation (cm ³ /rev)	Discharge flow (ℓ/min)		Allowable pressure (MPa)	Allowable rotation speed (rpm)	Weight (Kg)
		1500rpm	1800rpm			
11S	1.6	2.4	2.9	0.5	300 ~ 2000	0.7
12S	2.5	3.7	4.5	0.5	300 ~ 2000	0.8
13S	4.5	6.7	8.1	0.5	300 ~ 2000	1.0
11SVB	1.6	2.4	2.9	0.5	300 ~ 2000	1.0
12SVB	2.5	3.7	4.5	0.5	300 ~ 2000	1.0
13SVB	4.5	6.7	8.1	0.5	300 ~ 2000	1.1

Type	A	B	C	TL	D (Port Dia)	
					INLET	OUTLET
11S	25.5	11.5	10	61	PT 1/8"	PT 1/8"
12S	30.5	11.5	10	66	PT 1/4"	PT 1/4"
13S	45	5	14.5	78.5	PT 3/8"	PT 3/8"
11SVB	25.5	11.5	10	74	PT 1/8"	PT 1/8"
12SVB	30.5	11.5	10	79	PT 1/4"	PT 1/4"
13SVB	45	5	14.5	91.5	PT 3/8"	PT 3/8"

Application 適用	Material 材質
<ul style="list-style-type: none"> • Fluid: Oils • Kinematic viscosity (at 40°C) : 20 ~ 220 cSt • Operating temperature : 80°C Below 	<ul style="list-style-type: none"> • Pump body : Cast iron • Pump cover : Cast iron • Shaft : Steel • Rotor : Powder steel • Oil-seal : NBR (ø8×ø22×7t)



ATP - 204 HA VB - 1.5

- | | | | | |
|-----------------------|---------------------------------|---------------------------|------------------------|----------------------|
| ① | ② | ③ | ④ | ⑤ |
| ① ARYUNG T-Rotor Pump | ② Pump classification / ポンプ分類 | ③ Fastening method / 固定方法 | ④ Relief Valve / リリーフ弁 | ⑤ Set pressure (MPa) |
| | HA : Dedicated motor connection | HAB : BRACKET | VB : mounting / 実装 | VD : Drain Block |
| | HAF : FLANGE | | No mark : none / なし | |

- ATP-HA type pump has excellent durability by applying double oil-seal for shaft sealing device.
- When using as a heat medium, it can be used at high temperatures below 180°C by applying a fluorine-based oil-seal. (Optional)
- Relief valve that can control pressure is attached, so it can be used safely by reducing the load on the motor and pump (optional).
- It is suitable for oil and fuel transfer, lubrication of machine tools and various industrial machines, and hydraulic equipment.

- ATP-HAタイプのポンプは、シャフトシール装置にダブルオイルシールを採用することで耐久性に優れています。
- 熱媒体として使用する場合、フッ素系オイルシールを適用することにより、180°C以下の高温で使用できます。(オプション)
- 圧力制御が可能なリリーフバルブが付属しているため、モーターやポンプの負荷を軽減して安全に使用できます(オプション)。
- オイルや燃料の移送、工作機械や各種産業機械の潤滑、油圧機器に適しています。

Type	Perotation (cm ³ /rev)	Discharge flow (ℓ/min)		Allowable pressure (MPa)	Allowable rotation speed (rpm)	Weight (Kg)	
		1500rpm	1800rpm			HA HAF	HAVB HAVD
ATP-204HA	4.2	6.3	7.5	3.0	300 ~ 2500	3.2	3.6
ATP-206HA	6.0	9.0	10.8	3.0	300 ~ 2500	3.2	3.6
ATP-208HA	8.4	12.6	15.1	3.0	300 ~ 2500	3.3	3.7
ATP-210HA	10.2	15.3	18.3	3.0	300 ~ 2500	3.4	3.8
ATP-212HA	12.0	18.0	21.6	3.0	300 ~ 2000	3.6	4.0
ATP-216HA	16.2	24.3	29.1	3.0	300 ~ 1800	3.8	4.2
ATP-220HA	19.8	29.7	35.6	3.0	300 ~ 1800	4.1	4.5

Application 適用	Material 材質	
<ul style="list-style-type: none"> • Fluid: Oils • Kinematic viscosity (40°C standard): 20 ~ 220 cSt • Use temperature <ul style="list-style-type: none"> - NBR: 80°C below - FKM: 180°C below 	<ul style="list-style-type: none"> • Pump body : Cast iron • Port housing : Cast iron • Pump cover : Cast iron • Bearing : #6202zz, #6301zz • Shaft : Steel 	<ul style="list-style-type: none"> • Rotor : Powder steel • Oil-seal : NBR, FKM(Optional) <ul style="list-style-type: none"> - Ø15×Ø35×7t, - Ø17×Ø30×7t • Relief valve : Cast iron etc.

Appearance | 外觀

ATP-HA

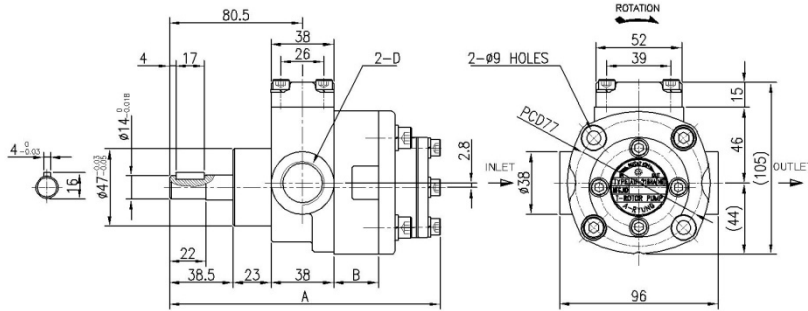

ATP-HAF

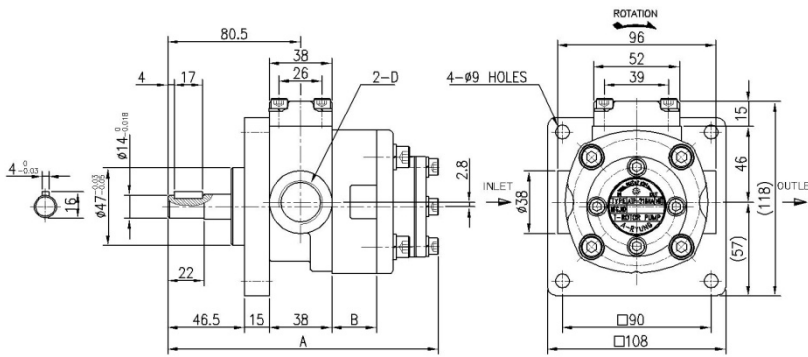

ATP-HABVB

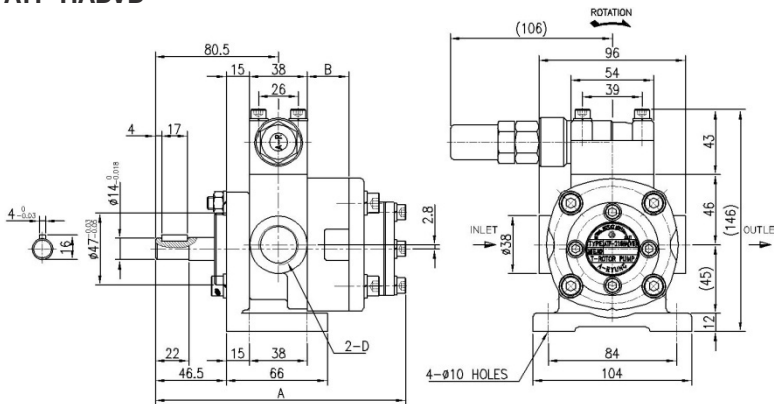

ATP-HABVD

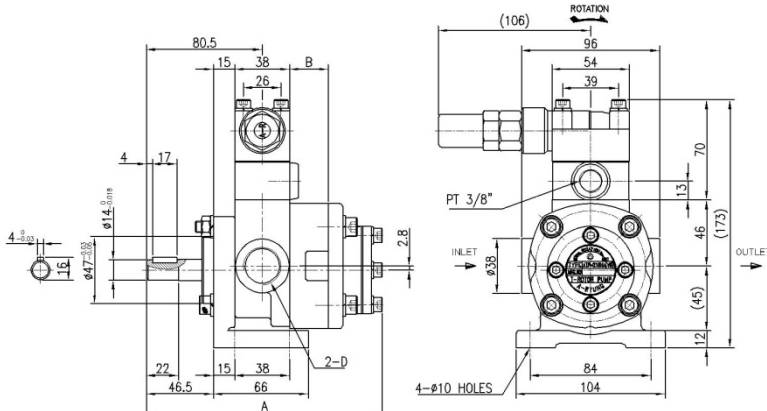

Type		A	B	D (Port Dia)	
				INLET	OUTLET
ATP-204	HA HAB HAF HAVB HAVD	145	7	PT 1/2"	
ATP-206	HA HAB HAF HAVB HAVD	148	10	PT 1/2"	
ATP-208	HA HAB HAF HAVB HAVD	152	14	PT 1/2"	
ATP-210	HA HAB HAF HAVB HAVD	155	17	PT 3/4"	
ATP-212	HA HAB HAF HAVB HAVD	158	20	PT 3/4"	
ATP-216	HA HAB HAF HAVB HAVD	165	27	PT 3/4"	
ATP-220	HA HAB HAF HAVB HAVD	171	33	PT 3/4"	

Performance curve | パフォーマンスカーブ

ATP-204HA(VB/VD)

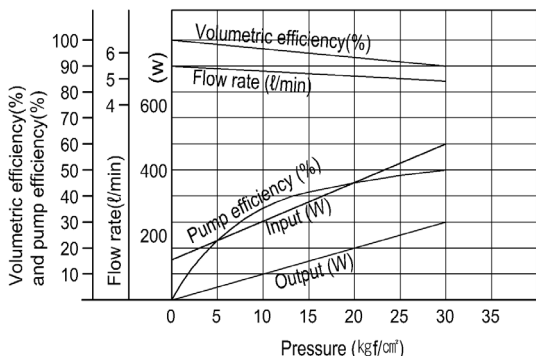

ATP-206HA(VB/VD)

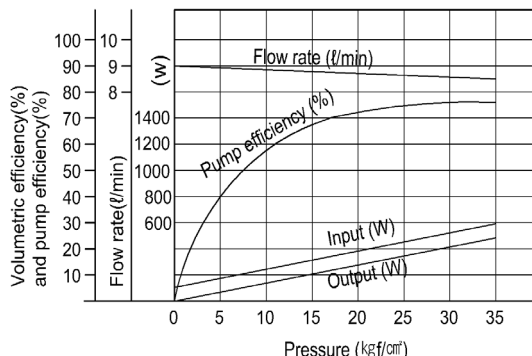

ATP-208HA(VB/VD)

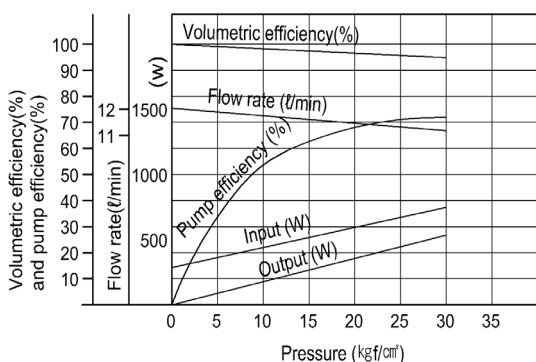

ATP-210HA(VB/VD)

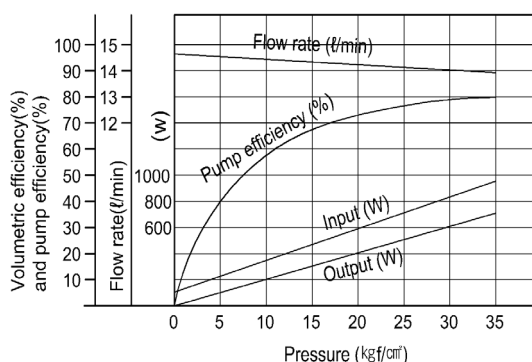

ATP-212HA(VB/VD)

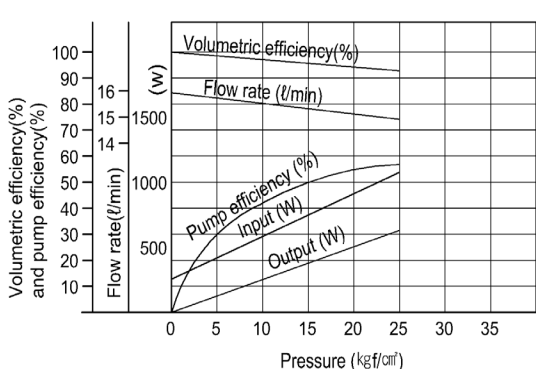

ATP-216HA(VB/VD)

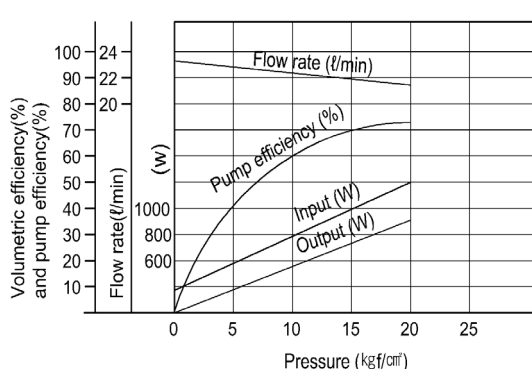

ATP-220HA(VB/VD)

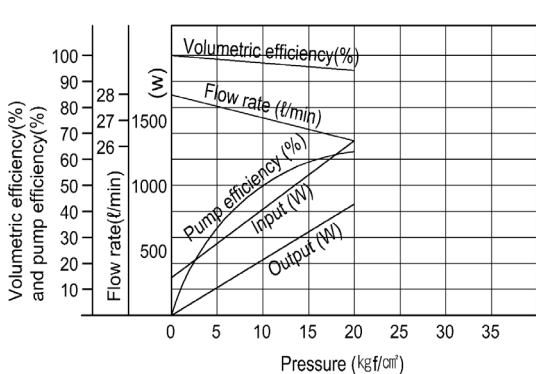

Fluid used	#46 turbine oil
Oil temperature	40°C
Rotation speed	1500rpm



ATP-320 H VB-1.0

- ①
- ②
- ③
- ④
- ⑤

- ① ARYUNG T-Rotor Pump
- ② Pump classification/ ポンプ分類
- ③ Fastening method / 固定方法
H: BRACKET
HF: FLANGE
- ④ Relief Valve / リリーフ弁
- ⑤ Set pressure / 設定圧力 (MPa)

- ATP-320HVB type pump has excellent durability by applying heat resistant oil-seal, and when used as a heat medium, it can be used at high temperatures below 180°C.
- Relief valve that can control pressure is attached, so it can be used safely by reducing the load on the motor and pump.
- It is suitable for oil and fuel transfer, lubrication and hydraulic system of machine tools and various industrial machines.

- ATP-320HVBタイプのポンプは、耐熱オイルシールを採用することで耐久性に優れ、熱媒体として使用すると180°C以下の高温で使用できます。
- 圧力制御が可能なリリーフバルブが付属しているので、モーターやポンプの負荷を軽減して安全に使用できます。
- 工作機械や各種産業機械のオイル・燃料移送、潤滑、油圧システムに適しています。

Type	Perotation (cm ³ /rev)	Discharge flow (ℓ/min)		Allowable pressure (MPa)	Allowable rotation speed (rpm)	Weight (Kg)
		1500rpm	1800rpm			
ATP-320HVB	26.0	39.0	46.8	3.0	1800	16.4
ATP-320HFVB						
ATP-340HVB	52.0	78.0	93.6	3.0	1500	17.0
ATP-340HFVB						

Performance curve | パフォーマンスカーブ

ATP-320HVB/HFVB

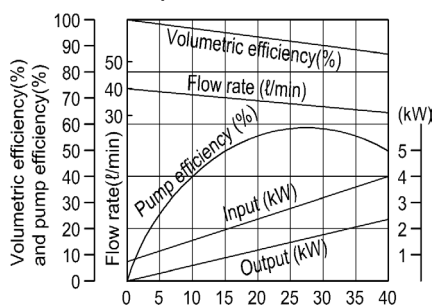

ATP-340HVB/HFVB

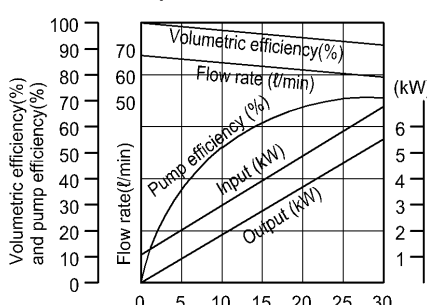

Fluid used	#46 turbine oil
Oil temperature	40°C
Rotation speed	1500rpm

Type	D(Port dia)	D(Port dia)	
		INLET PT	OUTLET PT
ATP-320	HVB HFVB	1"	1"
ATP-340	HVB HFVB	1 1/4"	1"

Appearance | 外観

ATP-320/340HVB

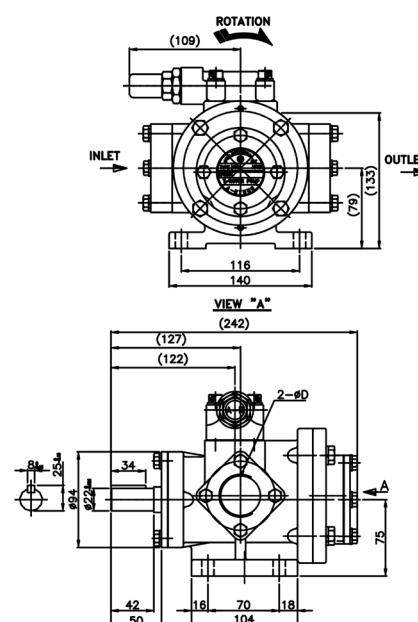



ATP-420 H VB-1.0

- ①
- ②
- ③
- ④
- ⑤

- ① ARYUNG T-Rotor Pump
- ② Pump classification / ポンプ分類
- ③ Relief Valve / リリーフ弁
- ④ Set pressure / 設定圧力 (MPa)

- As a large flow pump, it is suitable for transporting various oils such as ships and industrial machinery, bunker C fuel, and liquid with lubrication.
- Relief valve that can control pressure is attached, so it can be used safely by reducing the load on the motor and pump.

- 大型フローポンプとして、船舶や産業機械、バンカーC燃料、潤滑液などの各種油の輸送に適しています。
- 圧力制御が可能なリリーフバルブが付属しているため、モーターやポンプの負荷を軽減して安全に使用できます。

Appearance | 外観

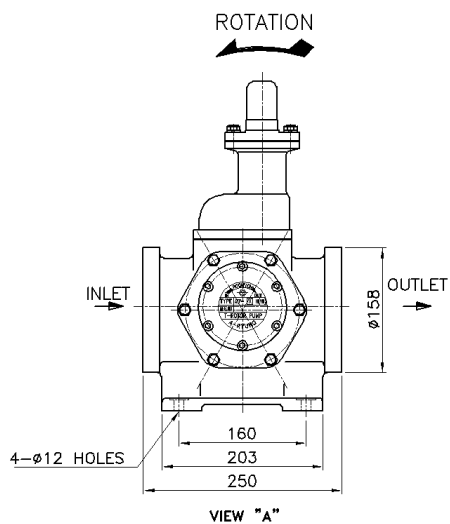

Type	Perotation (cm ³ /rev)	Discharge flow (ℓ/min)			Allowable pressure (MPa)	Allowable rotation speed (rpm)	Weight (Kg)
		1000rpm	1200rpm	1800rpm			
ATP-420HVB	90	90	108	162	0.5	1800	44.0
ATP-440HVB	180	180	216	-	0.3	1200	45.0

※ Data preparation in "Table" is based on fluid VG46, and when using a fluid with a higher viscosity than this, the power must be properly increased.

※ 「表」のデータ作成は流体VG46に基づいており、これよりも粘度の高い流体を使用する場合は、出力を適切に上げる必要があります。

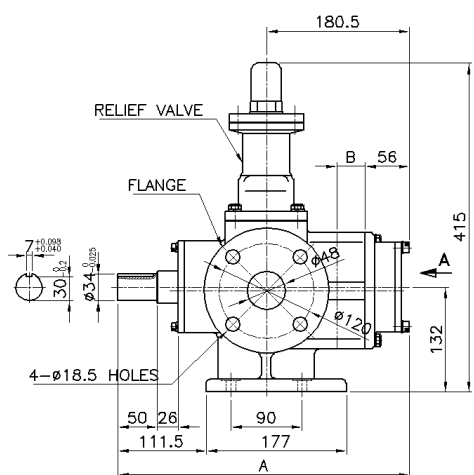

Application 適用	Material 材質
<ul style="list-style-type: none"> • Fluid used : Oils • Viscosity (at 40°C) - 400cSt: 1800rpm - 500cSt: 1500rpm - 1000cSt: 1200rpm Below • Use temperature : 0°C ~ 180°C 	<ul style="list-style-type: none"> • Pump body : Cast iron • Port housing : Cast iron • Pump cover : Cast iron • Bearing : #6208zz, 6207zz • Shaft : Steel • Rotor : Powder steel • Oil-seal : FKM (Ø40×Ø62×11t) • O-Ring : NBR • Relief valve : Cast iron etc.

System configuration example | システム構成例

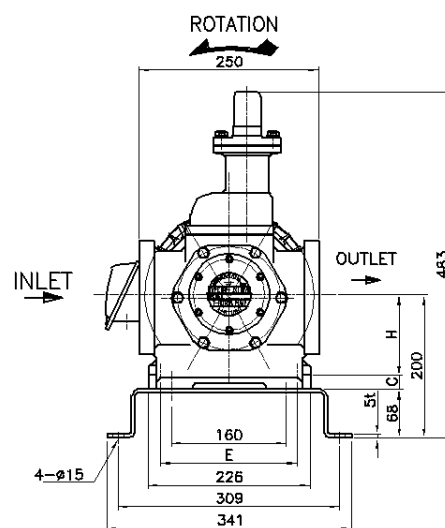
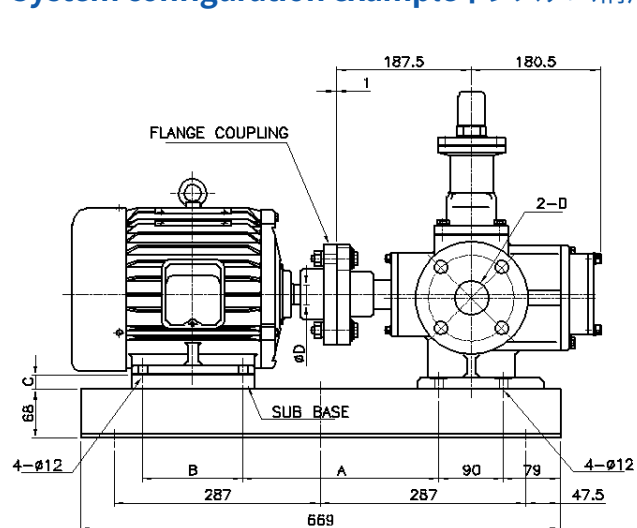

Type	A	B	C	ØD	E	H	D (Port dia) (KS10K-50A)	
							INLET	OUTLET
2.2kW(3Hp 6p)	273.5	140	20	28	190	112	2"(50A)	2"(50A)
3.7kW(5Hp 4p)	273.5	140	20	28	190	112	2"(50A)	2"(50A)
3.7kW(5Hp 6p)	312.5	140	-	38	216	132	2"(50A)	2"(50A)

※ The dimensions of the applied motor are based on a standard motor manufactured in Korea, but the specifications may be different depending on the manufacturer, so it must be checked and applied.

※ 適用モーターの寸法は韓国製の標準モーターを基準としていますが、メーカーによって仕様異なる場合がありますので、確認・適用が必要です。

Assembly Base

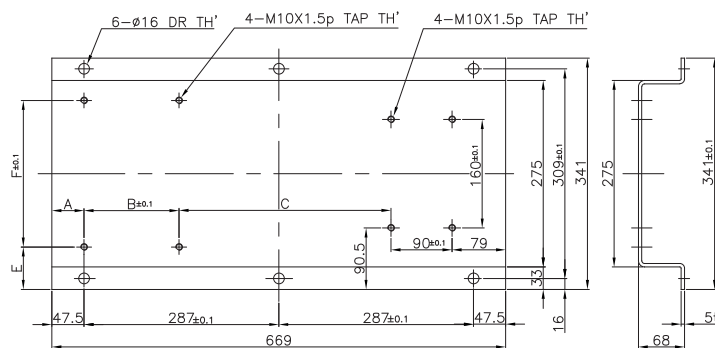

Type	A	B	C	E	F	G	Sub Base
2.2kW(3Hp 6p)	86.5	140	273.5	75.5	190	28	○
3.7kW(5Hp 4p)	86.5	140	273.5	75.5	190	28	○
3.7kW(5Hp 6p)	47.5	140	312.5	62.5	216	38	×

Sub Base

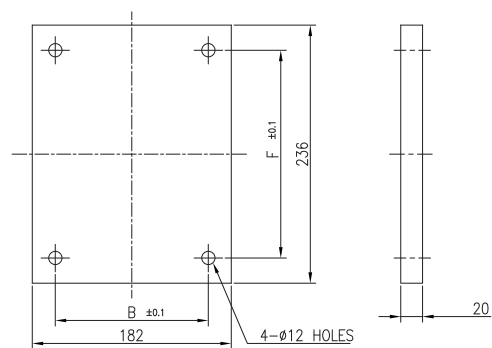

Flange Flexible Coupling (#140)

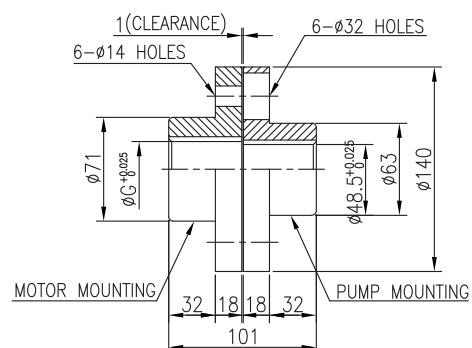



AMTP-200-12 MS F VB

① ② ③ ④ ⑤ ⑥

- ① ARYUNG Motor T-Rotor Pump
- ② Motor output / モーター出力
- ③ Pump classification / ポンプ分類
- ④ Motor classification / モーター分類
MS: 3Phase
MT: 1Phase
- ⑤ Fastening method / 固定方法
No mark: None
F: Flange
- ⑥ Relief Valve / リリーフ弁
VB: Apply / 適用
No mark: None

- AMTP-MS and MT type pumps are compact T-ROTOR pumps, which are designed to be compact by combining the motor and pump as an integral type, and the combination and separation of the motor and pump are easy, so maintenance is very easy.
- A relief valve that can control pressure is attached, so it can be used safely by reducing the load on the motor and pump (optional).
- Suitable for lubrication and fluid transfer of machine tools and various industrial machines.

- AMTP-MS、MTタイプのポンプはコンパクトなT-ROTORポンプで、モーターとポンプを一体型として組み合わせることでコンパクトに設計されており、モーターとポンプの組み合わせや分離が容易で、メンテナンスが非常に簡単です。
- 圧力制御が可能なリリーフバルブが付属しているので、モーターやポンプの負荷を軽減して安全に使用できます(オプション)。
- 工作機械や各種産業機械の潤滑や流体移送に適しています。

Pump Spec'

Type	1500 rpm (50Hz, 4p)			1800 rpm (60Hz, 4p)			Net Weight (Kg)
	Discharge Volume (ℓ/min)	Max' pressure per Motor Output (MPa)		Discharge Volume (ℓ/min)	Max' pressure per Motor Output (MPa)		
		100W	200W		100W	200W	
AMTP-11 MS(MT) / VB	2.4	0.5	-	2.9	0.5	-	8.2 / 8.5
AMTP-12 MS(MT) / VB	3.7	0.5	0.5	4.5	0.5	0.5	8.2 / 8.6
AMTP-13 MS(MT) / VB	6.7	-	0.5	8.1	-	0.5	8.6 / 8.7

Motor Spec'

Motor Output (W)	Frequency (Hz)	Voltage (V)	Current (A)	Rpm	Phase (Ø)	Poles (P)
100W	50	200 / 380	0.65 / 0.38	1430	3	4
	60	220 / 380 / 440	0.60 / 0.38 / 0.30	1720		
200W	50	200 / 380	1.3 / 0.75	1430	3	4
	60	220 / 380 / 440	1.1 / 0.75 / 0.55	1710		
200W	60	220	3.0	1745	1	4

■ Protection class / 保護等級 : IP44 ■ Insulation class / 絶縁階級 : B

Appearance | 外觀

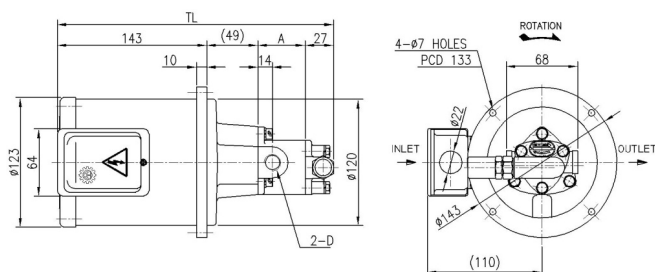

Type	A	TL	D (Port Dia)	
			INLET	OUTLET
12MSFVB	30.5	249	PT 1/4"	PT 1/4"
13MSFVB	45	264	PT 3/8"	PT 3/8"

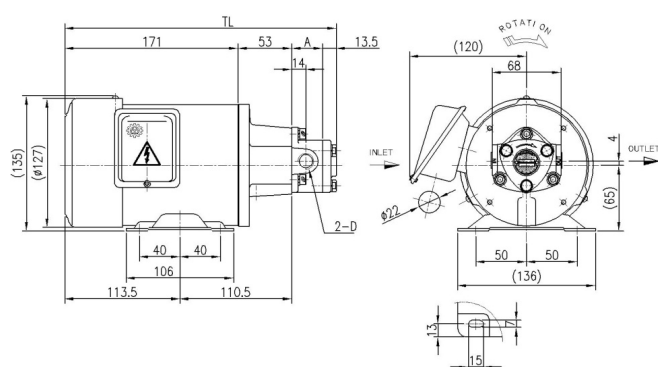

Type	A	TL	D (Port Dia)	
			INLET	OUTLET
11MS/MT	27.5	265	PT 1/8"	PT 1/8"
12MS/MT	30.5	268	PT 1/4"	PT 1/4"
13MS/MT	45	282.5	PT 3/8"	PT 3/8"

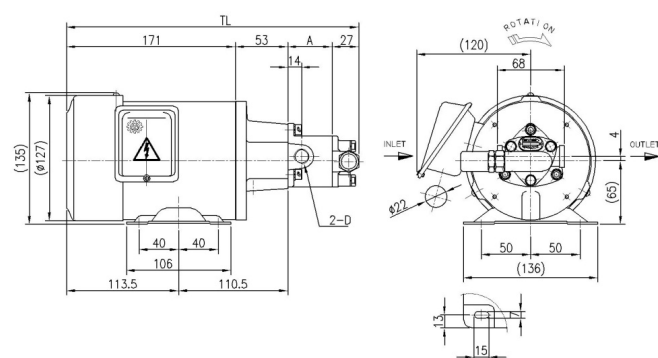

Type	A	TL	D (Port Dia)	
			INLET	OUTLET
11MSVB 11MTVB	27.5	278.5	PT 1/8"	PT 1/8"
12MSVB 12MTVB	30.5	281.5	PT 1/4"	PT 1/4"
13MSVB 13MTVB	45	296	PT 3/8"	PT 3/8"

Application | 適用

- Fluid: Oils
- Kinematic viscosity (40°C standard/standard)
: 20 ~ 220 cSt
- Use temperature
- NBR : 80°C Below

Material | 材質

- Motor Flame : Steel
- Pump Body : Cast iron
- Pump Cover : Cast iron
- Shaft : Steel
- Rotor : Powder steel
- Oil-Seal : Ø8×Ø22×7t
- NBR
- FKM (Option)



AMTP-750-204HA VB-1.5

① ② ③ ④ ⑤

- ① ARYUNG Motor T-Rotor Pump
- ② Motor output / モーター出力
- ③ Pump classification / ポンプ分類
- ④ Relief Valve / 压力调节阀
 VB : apply / 適用
 VD : Drain Block
 No mark : None
- ⑤ Set pressure / 設定圧力

- AMTP-HA type pump is manufactured in a compact form by combining a motor and a pump, so it is less restricted in the installation location, and it is easy to maintain and repair as the motor and pump are easily combined and separated.
- Double application of oil-seal for shaft sealing device, excellent durability.
- When using as a heat medium, it can be used at high temperatures below 180°C by applying a fluorine-based oil-seal. (Optional)
- A relief valve that can control pressure is attached, so it can be used safely by reducing the load on the motor and pump (optional).
- It is suitable for oil and fuel transfer, lubrication, and hydraulic system of machine tools and various industrial machines.

- AMTP-HAタイプのポンプは、モーターとポンプを組み合わせてコンパクトに製造されているため、設置場所の制約が少なく、モーターとポンプの組み合わせや分離が容易で、メンテナンスや修理が容易です。
- シャフトシール装置にオイルシールを2重適用し、耐久性に優れています。
- 熱媒体として使用する場合、フッ素系オイルシールを適用することにより、180°C以下の高温で使用できます。(オプション)
- 圧力制御が可能なリリーフバルブが付属しているため、モーターやポンプの負荷を軽減して安全に使用できます。(オプション)
- 工作機械や各種産業機械のオイル・燃料移送、潤滑、油圧システムに適しています。

Pump Spec'

Type	1500 rpm (50Hz, 4p)				1800 rpm (60Hz, 4p)				Net Weight (Kg)
	Discharge Volume (ℓ/min)	Max' pressure per Motor Output (MPa)			Discharge Volume (ℓ/min)	Max' pressure per Motor Output (MPa)			
		400W	750W	1500W		400W	750W	1500W	
AMTP-204HA	6.3	2.15	3.0	3.0	7.5	1.6	3.0	3.0	3.6
AMTP-206HA	9.0	0.7	2.5	2.5	10.8	0.7	2.35	2.5	3.6
AMTP-208HA	12.6	0.45	2.3	2.5	15.1	0.4	1.75	2.5	3.7
AMTP-210HA	15.3	0.35	1.55	2.5	18.3	0.25	1.15	2.5	3.8
AMTP-212HA	18.0	0.2	1.35	2.0	21.6	-	0.85	2.0	4.0
AMTP-216HA	24.3	-	0.85	2.0	29.1	-	0.55	1.95	4.2
AMTP-220HA	29.7	-	0.55	1.55	35.6	-	0.35	1.4	4.5

Motor Spec'

Motor Output (W)	Frequency (Hz)	Voltage (V)	Current (A)	Motor speed (rpm)	Phase (Ø)	Poles (P)	Net Weight (Kg)
400W	50	200 / 380 / 415	2.2 / 1.3 / 1.1	1420	3	4	13.2
	60	220 / 380 / 440	2.0 / 1.2 / 1.0	1710			
750W	50	200 / 380 / 415	3.6 / 2.0 / 1.7	1440	3	4	17.6
	60	220 / 380 / 440	3.2 / 1.9 / 1.6	1720			
1500W	50	200 / 380 / 415	6.3 / 3.3 / 3.1	1430	3	4	23.6
	60	220 / 380 / 440	6.1 / 3.5 / 3.0	1730			

■ Protection class / 保護等級 : IP44 ■ Insulation class / 絶縁階級 : B - 400W , F - 750W, 1500W

Appearance | 外觀

AMTP-HA

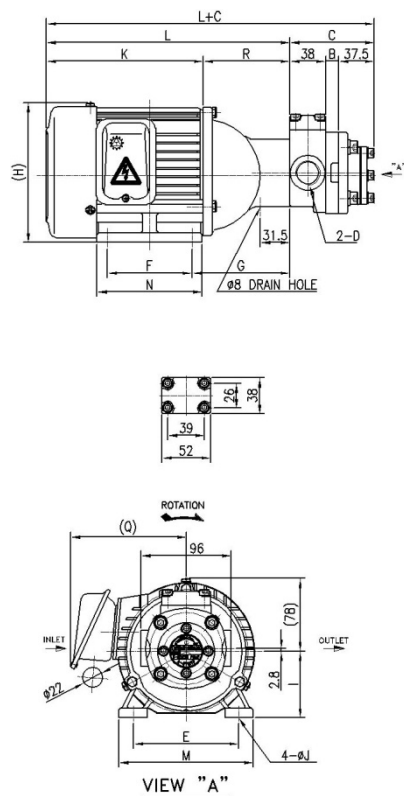

AMTP-HAVB

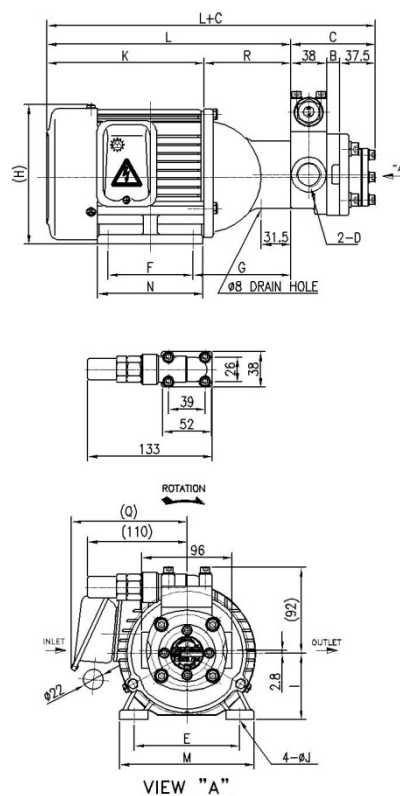

AMTP-HAVD

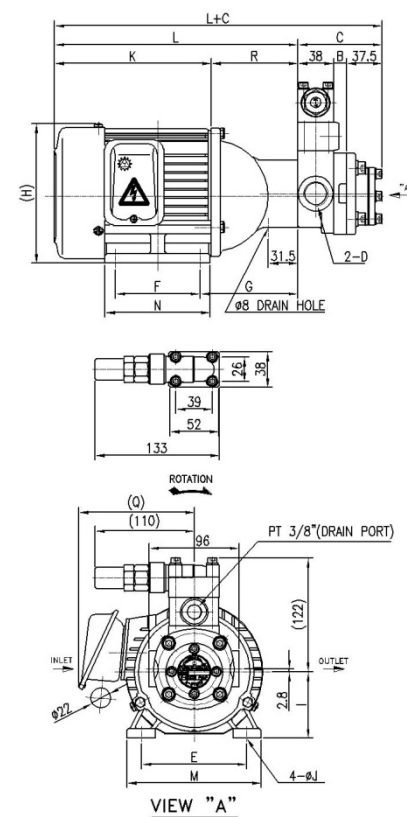

Type	E	F	G	H	I	K	L	M	N	Q	R
400W	112	90	104.5	150	71	167	273.5	143	120	125	92.5
750W	125	100	112.5	169	80	206	301	167	135	145	92.5
1500W	140	125	107.5	193	90	230	334	172	155	155	89

Type	B	C	D (Port Dia)	
			INLET	OUTLET
AMTP-204 HA / HAVB / HAVD	7	82.5	PT 1/2"	PT 1/2"
AMTP-206 HA / HAVB / HAVD	10	85.5	PT 1/2"	PT 1/2"
AMTP-208 HA / HAVB / HAVD	14	89.5	PT 1/2"	PT 1/2"
AMTP-210 HA / HAVB / HAVD	17	92.5	PT 3/4"	PT 3/4"

Type	B	C	D (Port Dia)	
			INLET	OUTLET
AMTP-212 HA / HAVB / HAVD	20	95.5	PT 3/4"	PT 3/4"
AMTP-216 HA / HAVB / HAVD	27	102.5	PT 3/4"	PT 3/4"
AMTP-220 HA / HAVB / HAVD	33	108.5	PT 3/4"	PT 3/4"

Application 適用	Material 材質
<ul style="list-style-type: none"> Fluid: Oils Kinematic viscosity (at 40°C): 20 ~ 220 cSt Use temperature <ul style="list-style-type: none"> - NBR: 80°C below - FKM: 180°C below 	<ul style="list-style-type: none"> Pump body : Cast iron Port housing : Cast iron Pump cover : Cast iron Bearing : #6202zz, #6301zz Shaft : Steel
	<ul style="list-style-type: none"> Rotor : Powder steel Oil-seal : NBR, FKM(Optional) <ul style="list-style-type: none"> - Ø15×Ø35×7t, - Ø17×Ø30×7t Relief valve : Cast iron etc.



AMTP - 750 - 206HAVBF - 1.5

① ② ③ ④

- ① ARYUNG Motor T-Rotor Pump
- ② Motor output / モーター出力
- ③ Pump classification / ポンプ分類
- ④ Set pressure / 設定圧力

- AMTP-HAVBF type pump is equipped with a suction filter on its own, so it does not need a separate filter device, and it always sucks and discharges clean fluid to prevent abrasion and damage of the rotor, thereby extending the life of the pump.
- Double application of oil-seal for shaft sealing device, excellent durability.
- The built-in filter is equipped with a gauge so that the replacement timing can be easily identified, and the filter type can be reused by washing it in an element type.
- A relief valve that can control pressure is attached, so it can be used safely by reducing the load on the motor and pump.
- Suitable for oil and fuel transfer and lubrication of machine tools and various industrial machines.

- AMTP-HAVBFタイプのポンプは、サクションフィルターを内蔵しているため、別途フィルター装置を必要とせず、ローターの摩耗や損傷を防ぐため、常に清浄な液体を吸込・排出することで、ポンプの寿命を延ばします。
- シャフトシール装置にオイルシールを2重適用し、耐久性に優れています。
- フィルターはゲージを内蔵しているので交換時期がわかりやすく、フィルタータイプはエレメントタイプで洗浄して再利用できます。
- 圧力制御が可能なリリーフバルブが付属しているので、モーターやポンプの負荷を軽減して安全に使用できます。
- 工作機械や各種産業機械のオイルや燃料の移送や潤滑に適しています。

Pump Spec'

Type	1500 rpm (50Hz, 4p)				1800 rpm (60Hz, 4p)				Net Weight (Kg)
	Discharge Volume (ℓ/min)	Max' pressure per Motor Output (MPa)			Discharge Volume (ℓ/min)	Max' pressure per Motor Output (MPa)			
		400W	750W	1500W		400W	750W	1500W	
AMTP-204HAVBF	6.3	1.5	1.5	1.5	7.5	1.5	1.5	1.5	7.2
AMTP-206HAVBF	9.0	0.7	1.5	1.5	10.8	0.7	1.5	1.5	7.2
AMTP-208HAVBF	12.6	0.45	1.5	1.5	15.1	0.4	1.5	1.5	7.3
AMTP-210HAVBF	15.3	0.35	1.5	1.5	18.3	0.25	1.15	1.5	7.4
AMTP-212HAVBF	18.0	0.2	1.5	1.5	21.6	-	0.85	1.5	7.6
AMTP-216HAVBF	24.3	-	0.85	1.5	29.1	-	0.55	1.5	7.8
AMTP-220HAVBF	29.7	-	0.55	1.5	35.6	-	0.35	1.4	8.1

Motor Spec'

Motor Output (W)	Frequency (Hz)	Voltage (V)	Current (A)	Motor speed (rpm)	Phase (Ø)	Poles (P)	Net Weight (Kg)
400W	50	200 / 380 / 415	2.2 / 1.3 / 1.1	1420	3	4	13.2
	60	220 / 380 / 440	2.0 / 1.2 / 1.0	1710			
750W	50	200 / 380 / 415	3.6 / 2.0 / 1.7	1440	3	4	17.6
	60	220 / 380 / 440	3.2 / 1.9 / 1.6	1720			
1500W	50	200 / 380 / 415	6.3 / 3.3 / 3.1	1430	3	4	23.6
	60	220 / 380 / 440	6.1 / 3.5 / 3.0	1730			

■ Protection class / 保護等級: IP44

■ Insulation class / 絶縁階級: B - 400W, F - 750W, 1500W

Appearance | 外観

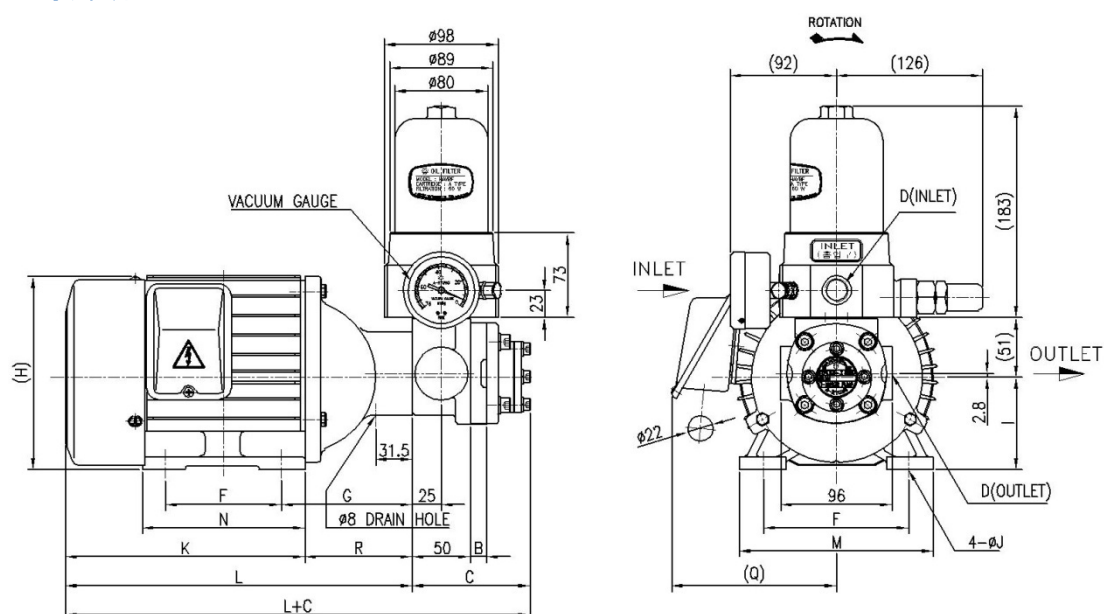

Type	E	F	G	H	I	K	L	M	N	Q	R
400W	112	90	104.5	150	71	167	259.5	143	120	125	92.5
750W	125	100	112.5	169	80	206	298.5	167	135	145	92.5
1500W	140	125	107.5	193	90	230	319	172	155	155	89

Type	B	C	D (Port Dia)	
			INLET	OUTLET
AMTP-204HAVBF	7	94.5	PT 1/2"	PT 1/2"
AMTP-206HAVBF	10	97.5	PT 1/2"	PT 1/2"
AMTP-208HAVBF	14	101.5	PT 1/2"	PT 1/2"
AMTP-210HAVBF	17	104.5	PT 3/4"	PT 3/4"

Type	B	C	D (Port Dia)	
			INLET	OUTLET
AMTP-212HAVBF	20	107.5	PT 3/4"	PT 3/4"
AMTP-216HAVBF	27	114.5	PT 1"	PT 1"
AMTP-220HAVBF	33	120.5	PT 1"	PT 1"

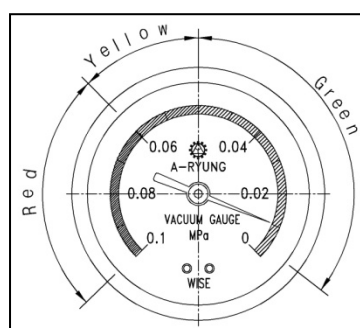

Filter cleaning and replacement timing | フィルターの清掃と交換のタイミング

When replacing the filter, identify it with the scale of the vacuum gauge and replace or clean it in a timely manner.

- Red: Exchange/wash • Yellow: Caution • Green: normal

フィルタを交換するときは、バキュームゲージの目盛りで識別し、適時に交換または清掃してください。

- 赤: 交換 / 洗浄 • 黄色: 注意 • 緑: 通常

Application 適用	Material 材質	
<ul style="list-style-type: none"> • Fluid: Oils • Kinematic viscosity (at 40°C): 20 ~ 220 cSt • Use temperature <ul style="list-style-type: none"> - NBR: 80°C below - FKM: 180°C below 	<ul style="list-style-type: none"> • Motor frame: Aluminum • Pump body: Cast iron • Port housing: Cast iron • Pump cover: Cast iron • Bearing: #6202zz, #6301zz 	<ul style="list-style-type: none"> • Shaft: Steel • Rotor: Powder steel • Oil-seal: NBR, FKM(Optional) <ul style="list-style-type: none"> - Ø15×Ø35×7t, - Ø17×Ø30×7t

AMTP-750-216HA / 208HAVB-0.3



① ② ③ ④ ⑤

- ① ARYUNG Motor T-Rotor Pump
- ② Motor output / モーター出力
- ③ Primary side pump / 一次サイドポンプ
HA: Relief valve none / リリーフバルブなし
HAVB: Relief valve mounting / リリーフバルブの取り付け
- ④ Secondary pump / 二次ポンプ
HA: Relief valve none / リリーフバルブなし
HAVB: Relief valve mounting / リリーフバルブの取り付け
- ⑤ Set pressure / 設定圧力

- AMTP-HA-HAVB type pump is economical and compact by combining two pumps with a motor in a one-axis parallel type, and maintenance is very easy due to the simple combination and separation of pumps.
- Double application of oil-seal for shaft sealing device, excellent durability.
- When using as a heat medium, it can be used at high temperatures below 180°C by applying a fluorine-based oil-seal. (Optional)
- A relief valve that can control pressure is attached, so it can be used safely by reducing the load on the motor and pump (Optional).
- It is suitable for oil and fuel transfer, lubrication, and hydraulic system of machine tools and various industrial machines.

- AMTP-HA-HAVB式のポンプは、2台のポンプと1軸並列タイプのモーターを組み合わせることで経済的かつコンパクトになり、ポンプの組み合わせと分離が簡単のため、メンテナンスが非常に簡単です。
- シャフトシール装置にオイルシールを2重適用し、耐久性に優れています。
- 熱媒体として使用する場合、フッ素系オイルシールを適用することにより、180°C以下の高温で使用できます。(オプション)
- 圧力制御が可能なリリーフバルブが付属しているので、モーターやポンプの負荷を軽減して安全に使用できます(オプション)。
- 工作機械や各種産業機械のオイル・燃料移送、潤滑、油圧システムに適しています。

Pump Spec'

Type	1500 rpm (50Hz, 4p)					1800 rpm (60Hz, 4p)					Net Weight (Kg)
	Discharge Volume (ℓ/min)		Max' pressure per Motor Output (MPa)			Discharge Volume (ℓ/min)		Max' pressure per Motor Output (MPa)			
	P1	P2	400W	750W	1500W	P1	P2	400W	750W	1500W	
AMTP-206HA/206HAVB	9.0	9.0	0.4	1.6	3.3	10.8	10.8	0.3	1.3	2.7	5.9
AMTP-208HA/206HAVB	12.6	9.0	0.3	1.2	2.7	15.1	10.8	0.3	1.0	2.3	6.0
AMTP-208HA/208HAVB	12.6	12.6	0.2	1.0	2.3	15.1	15.1	0.2	0.9	1.9	6.1
AMTP-210HA/208HAVB	15.3	12.6	0.2	0.8	2.0	18.3	15.1	-	0.6	1.7	6.2
AMTP-210HA/210HAVB	15.3	15.3	0.2	0.7	1.8	18.3	18.3	-	0.6	1.5	6.3
AMTP-212HA/208HAVB	18.0	12.6	-	0.7	1.6	21.6	15.1	-	0.6	1.3	6.4
AMTP-212HA/210HAVB	18.0	15.3	-	0.6	1.5	21.6	18.3	-	0.5	1.2	6.5
AMTP-212HA/212HAVB	18.0	18.0	-	0.5	1.1	21.6	21.6	-	0.5	1.1	6.7
AMTP-216HA/208HAVB	24.3	12.6	-	0.4	1.2	29.1	15.1	-	0.3	1.1	6.6
AMTP-216HA/210HAVB	24.3	15.3	-	0.4	1.2	29.1	18.3	-	0.3	1.0	6.7
AMTP-216HA/212HAVB	24.3	18.0	-	0.4	1.1	29.1	21.6	-	0.3	0.9	6.9
AMTP-216HA/216HAVB	24.3	24.3	-	0.3	0.9	29.1	29.1	-	0.2	0.8	7.1
AMTP-220HA/208HAVB	29.7	12.6	-	0.24	0.72	35.6	15.1	-	0.2	0.6	6.7
AMTP-220HA/210HAVB	29.7	15.3	-	0.24	0.6	35.6	18.3	-	0.2	0.5	6.8
AMTP-220HA/212HAVB	29.7	18.0	-	0.19	0.54	35.6	21.6	-	0.16	0.15	7.0
AMTP-220HA/216HAVB	29.7	24.3	-	0.17	0.48	35.6	29.1	-	0.14	0.4	7.2
AMTP-220HA/220HAVB	29.7	29.7	-	0.15	0.45	35.6	35.6	-	0.12	0.37	7.3

Motor Spec'

Motor Output (W)	Frequency (Hz)	Voltage (V)	Current (A)	Motor speed (rpm)	Phase (Ø)	Poles (P)	Net Weight (Kg)
400W	50	200 / 380 / 415	2.2 / 1.3 / 1.1	1420	3	4	13.2
	60	220 / 380 / 440	2.0 / 1.2 / 1.0	1710			
750W	50	200 / 380 / 415	3.6 / 2.0 / 1.7	1440	3	4	17.6
	60	220 / 380 / 440	3.2 / 1.9 / 1.6	1720			
1500W	50	200 / 380 / 415	6.3 / 3.3 / 3.1	1430	3	4	23.6
	60	220 / 380 / 440	6.1 / 3.5 / 3.0	1730			

■ Protection class / 保護等級 : IP44 ■ Insulation class / 絶縁階級 : B - 400W , F - 750W, 1500W

Appearance | 外觀

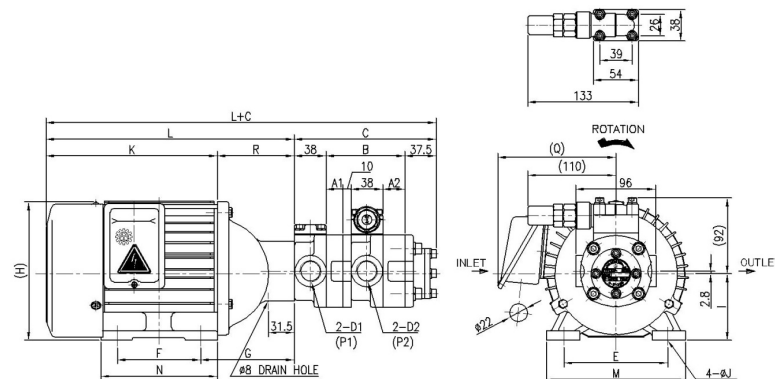

Type	E	F	G	H	I	J	K	L	M	N	Q	R
400W	112	90	104.5	150	71	10	167	259.5	143	120	125	92.5
750W	125	100	112.5	169	80	10	206	298.5	167	135	145	92.5
1500W	140	125	107.5	193	90	10	230	319	172	155	155	89

Type	B	C	A1	A2	In & Outlet	
					D1	D2
AMTP-204HA/206HAVB	68	143.5	10	10	PT 1/2"	PT 1/2"
AMTP-208HA/206HAVB	72	147.5	14	10	PT 1/2"	PT 1/2"
AMTP-208HA/208HAVB	76	151.5	14	14	PT 1/2"	PT 1/2"
AMTP-210HA/208HAVB	79	154.5	17	14	PT 3/4"	PT 1/2"
AMTP-210HA/210HAVB	82	157.5	17	17	PT 3/4"	PT 3/4"
AMTP-212HA/208HAVB	82	157.5	20	14	PT 3/4"	PT 1/2"
AMTP-212HA/210HAVB	85	160.5	20	17	PT 3/4"	PT 3/4"
AMTP-212HA/212HAVB	88	163.5	20	20	PT 3/4"	PT 3/4"
AMTP-216HA/208HAVB	89	164.5	27	14	PT 3/4"	PT 1/2"

Type	B	C	A1	A2	In & Outlet	
					D1	D2
AMTP-216HA/210HAVB	92	167.5	27	17	PT 3/4"	PT 3/4"
AMTP-216HA/212HAVB	95	170.5	27	20	PT 3/4"	PT 3/4"
AMTP-216HA/216HAVB	102	177.5	27	27	PT 3/4"	PT 3/4"
AMTP-220HA/208HAVB	95	170.5	33	14	PT 3/4"	PT 1/2"
AMTP-220HA/210HAVB	98	173.5	33	17	PT 3/4"	PT 3/4"
AMTP-220HA/212HAVB	101	176.5	33	20	PT 3/4"	PT 3/4"
AMTP-220HA/216HAVB	108	183.5	33	27	PT 3/4"	PT 3/4"
AMTP-220HA/220HAVB	114	189.5	33	33	PT 3/4"	PT 3/4"

Application 適用	Material 材質
<ul style="list-style-type: none"> Fluid: Oils Kinematic viscosity (at 40°C): 20 ~ 220 cSt Use temperature <ul style="list-style-type: none"> - NBR: 80°C below - FKM: 180°C below 	<ul style="list-style-type: none"> Motor Flame : Aluminum Pump body : Cast iron Port housing : Cast iron Pump cover : Cast iron Bearing : #6202zz, #6301zz
	<ul style="list-style-type: none"> Shaft : Steel Rotor : Powder steel Oil-seal : NBR, FKM(Optional) <ul style="list-style-type: none"> - Ø15×Ø35×7t, - Ø17×Ø30×7t



AMTP-200-204LN VA

① ② ③ ④

- ① ARYUNG Motor T-Rotor Pump
- ② Motor output / モーター出力
- ③ Pump classification / ポンプ分類
- ④ Relief Valve / リリーフ弁
 - VA : Standard
 - VB : Output Side
 - VT : Drain Type

- AMTP-LN type pump is designed to be compact by combining the motor and pump with a low noise structure, and it is very easy to maintain and repair as the combination and separation of the motor and pump are simple.
- Relief valve that can control pressure is attached, so it can be used safely by reducing the load on the motor and pump.
- Suitable for machine tool spindle oil circulation device, oil cone, oil transfer lubrication device, etc.

- AMTP-LNタイプのポンプは、モーターとポンプを低騒音構造で組み合わせることでコンパクトに設計されており、モーターとポンプの組み合わせや分離が簡単なため、メンテナンスや修理が非常に簡単です。
- 圧力制御が可能なリリーフバルブが付属しているため、モーターやポンプの負荷を軽減して安全に使用できます。
- 工作機械のスピンドルオイル循環装置、オイルコーン、オイルトランスファー潤滑装置などに適しています。

Pump Spec'

Type	1500 rpm (50Hz, 4p)				1800 rpm (60Hz, 4p)			
	Discharge Volume (ℓ/min)	Max' pressure per Motor Output (MPa)			Discharge Volume (ℓ/min)	Max' pressure per Motor Output (MPa)		
		200W	400W	700W		2400W	400W	700W
AMTP-204LN	6.3	0.4	0.6	0.6	7.5	0.4	0.6	0.6
AMTP-206LN	9.0	0.4	0.6	0.6	10.8	0.4	0.6	0.6
AMTP-208LN	12.6	0.4	0.6	0.6	15.1	0.4	0.6	0.6
AMTP-210LN	15.3	-	0.6	0.6	18.3	-	0.6	0.6
AMTP-212LN	18.0	-	0.6	0.6	21.6	-	0.6	0.6
AMTP-216LN	24.3	-	0.6	0.6	29.1	-	0.6	0.6
AMTP-220LN	29.7	-	-	0.6	35.6	-	-	0.6

Motor Spec'

Motor Output (W)	Frequency (Hz)	Voltage (V)	Current (A)	Motor speed (rpm)	Phase (Ø)	Poles (P)
200W	50	200 / 380	1.3 / 0.8	1420	3	4
	60	200 / 220 / 380	1.15 / 1.15 / 0.7	1720		
400W	50	200 / 380	2.4 / 1.5	1420	3	4
	60	200 / 220 / 380	2.3 / 2.3 / 1.4	1720		
700W	50	200 / 380 / 415	3.6 / 2.0 / 1.7	1420	3	4
	60	220 / 380 / 440	3.2 / 1.9 / 1.6	1720		

■ Protection class / 保護等級 : IP44

■ Insulation class / 絶縁階級 : B - 200W, 400W F - 750W

Appearance | 外觀

AMTP-LNVA

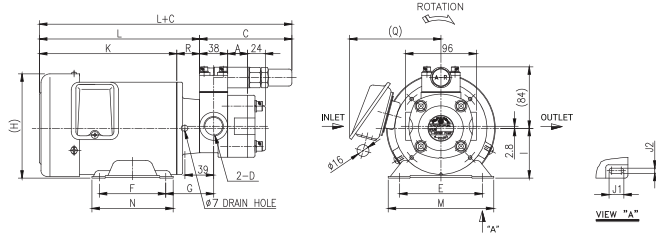

AMTP-LNVB

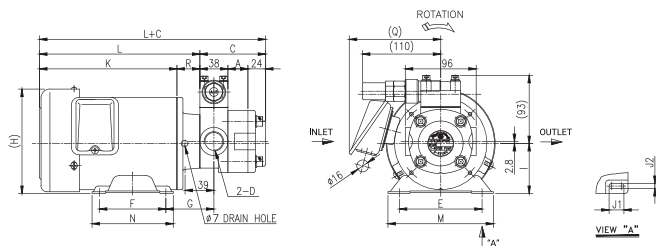

AMTP-LNVT

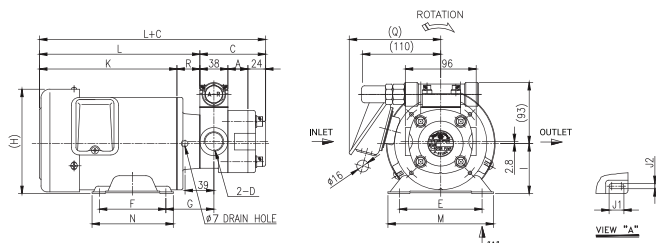

Type		B	C	D (Port Dia)	
				INLET	OUTLET
AMTP-204LN	VA	7	125	PT 1/2"	
	VB	7	69		
	VT	7	69		
AMTP-206LN	VA	10	125	PT 1/2"	
	VB	10	72		
	VT	10	72		
AMTP-208LN	VA	14	125	PT 1/2"	
	VB	14	76		
	VT	14	76		
AMTP-210LN	VA	17	125	PT 3/4"	
	VB	17	79		
	VT	17	79		
AMTP-212LN	VA	20	125	PT 3/4"	
	VB	20	82		
	VT	20	82		
AMTP-216LN	VA	27	125	PT 3/4"	
	VB	27	89		
	VT	27	89		
AMTP-220LN	VA	33	125	PT 3/4"	
	VB	33	95		
	VT	33	95		

Type	E	F	G	H	I	K	L	M	N	Q	R	J1	J2
200W	110	80	67.5	135	64.5	181	212	136	106	122	31	15	7
400W	112	90	65	145	67.5	186	217	143	110	128	31	20	7
700W	125	100	72	170	80.5	226	257	169	124	140	31	30	10

적용 应用	재질 材料
<ul style="list-style-type: none"> • 사용유체 / 使用介质 : Oils • 동점도 / 黏度 (40°C 기준/为准) : 2 ~ 100 cSt • 사용온도 / 使用温度 <ul style="list-style-type: none"> - NBR : 80°C 이하 / 以下 - FKM : 180°C 이하 / 以下 	<ul style="list-style-type: none"> • Motor frame : Steel • Pump body : Cast iron • Port housing : Cast iron • Pump cover : Cast iron • Shaft : Steel
	<ul style="list-style-type: none"> • Rotor : Powder steel • Oil-seal : NBR <ul style="list-style-type: none"> - Ø19×Ø35×7t • Relief valve : Cast iron etc.

AMTP- 1500 - 320LNVB - 0.5



- ①
- ②
- ③
- ④

- ① ARYUNG Motor T-Rotor Pump
- ② Motor output / モーター出力
- ③ Pump classification / ポンプ分類
- ④ Set pressure/ 設定圧力

- AMTP-LN type pump is designed to be compact by combining the motor and pump with a low noise structure, and it is very easy to maintain and repair as the combination and separation of the motor and pump are simple.
- Relief valve that can control pressure is attached, so it can be used safely by reducing the load on the motor and pump.
- Suitable for machine tool spindle oil circulation device, oil cone, oil transfer lubrication device, etc.

- AMTP-LN型ポンプは低騒音構造でモーターとポンプを組み合わせてコンパクトに設計されており、モーターとポンプの結合及び分離が容易でメンテナンスが非常に容易である。
- 圧力調整が可能なリリーフバルブが貼られており、モーターとポンプの負荷を軽減し、安全に使用することができる。
- 工作機械スピンドル油循環装置、オイルコーン、Oil移送潤滑装置などに適している。

Pump Spec'

Type	PUMP				MOTOR				
	1500 rpm (50Hz, 4p)		1800 rpm (60Hz, 4p)		Phase 3 Ø, Poles 4p				
	Discharge Volume (ℓ/min)	Max' pressure (MPa)	Discharge Volume (ℓ/min)	Max' pressure (MPa)	Output (Kw)	Frequency (Hz)	Voltage (V)	Current(A)	Motor speed (rpm)
AMTP-1500-320LNVB	39	0.75	46.8	0.75	1.5	50	200 / 380 / 415	6.3 / 3.3 / 3.1	1420
						60	220 / 380 / 440	6.1 / 3.5 / 3.0	1720

■ Protection class / 保護等級: IP44 ■ Insulation class/ 絶縁階級: F

Appearance | 外観

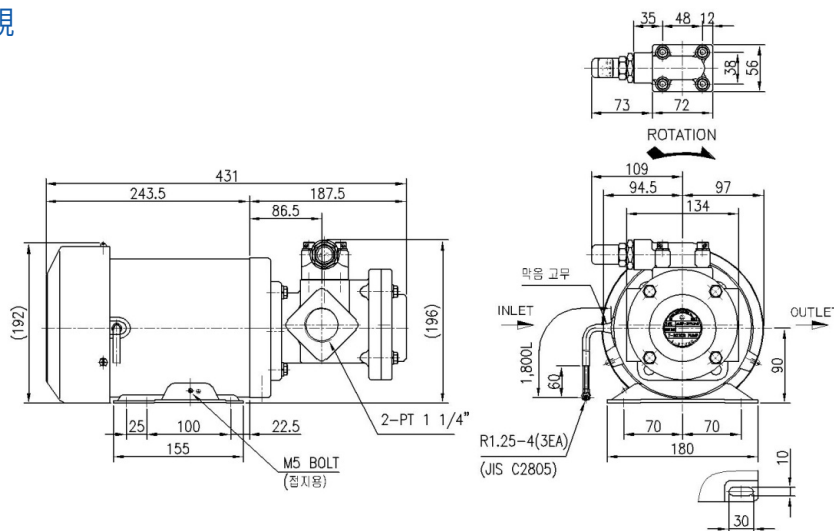

AMTP - HFVB - 320HF VB 0.5

① ② ③ ④ ⑤



- ① ARYUNG Motor T-Rotor Pump
- ② Motor output / モーター出力
- ③ Pump classification / ポンプ分類
- ④ Relief Valve / リリーフ弁
- ⑤ Set pressure/ 設定圧力

- AMTP-HFVB type pump is manufactured to be compact by combining motor and pump, and it is very easy to maintain and repair as it is easy to combine and separate the motor and pump.
- When using as a heat medium, it can be used at a high temperature below 180°C by applying a fluorine-based oil-seal.
- Relief valve that can control pressure is attached to reduce the load on the motor and pump, so it can be used safely.
- Suitable for oil and fuel transfer and lubrication of machine tools and various industrial machines.

- AMTP-HFVBタイプのポンプは、モーターとポンプを組み合わせてコンパクトに製造されており、モーターとポンプの組み合わせや分離が容易なため、メンテナンスや修理が非常に簡単です。
- 熱媒体として使用する場合は、フッ素系オイルシールを適用することにより、180°C以下の高温で使用できます。
- モーターやポンプへの負荷を軽減するため、圧力制御が可能なリリーフバルブを装備し、安全に使用できます。
- 工作機械や各種産業機械のオイルや燃料の移送や潤滑に適しています。

Pump Spec'

Type	1500 rpm (50Hz, 4p)			1800 rpm (60Hz, 4p)			Net Weight (Kg)
	Discharge Volume (ℓ/min)	Max' pressure (MPa)		Discharge Volume (ℓ/min)	Max' pressure (MPa)		
		1.5Kw	2.2Kw		1.5Kw	2.2Kw	
AMTP-320HFVB	39	0.5	0.8	46.8	0.5	0.8	14.7
AMTP-340HFVB	78	0.3	0.4	93.6	0.3	0.4	15.5

Type	1000 rpm (50Hz, 6p)			1200 rpm (60Hz, 6p)			Net Weight (Kg)
	Discharge Volume (ℓ/min)	Max' pressure (MPa)		Discharge Volume (ℓ/min)	Max' pressure (MPa)		
		1.5Kw	2.2Kw		1.5Kw	2.2Kw	
AMTP-320HFVB	26	0.8	1.2	31.2	0.8	1.2	14.7
AMTP-340HFVB	52	0.4	0.6	62.4	0.4	0.6	15.5

Motor Spec'

Motor Output (W)	Frequency (Hz)	Voltage (V)	Current (A)		Phase (Ø)	Net Weight (Kg)	
			Poles : 4p	Poles : 6p		4p	6p
100W	50	200 / 380 / 415	6.3 / 3.3 / 3.1	7.8 / 4.1 / 3.8	3	22.4	30.5
	60	220 / 380 / 440	6.1 / 3.5 / 3.0	6.7 / 3.9 / 3.4			
200W	50	200 / 380 / 415	8.8 / 4.7 / 4.3	11.0 / 5.8 / 5.3	3	30.7	35.5
	60	220 / 380 / 440	8.3 / 4.8 / 4.1	8.9 / 5.1 / 4.4			

■ Protection class / 保護等級 : IP44 ■ Insulation class / 絶縁階級 : F

Appearance | 外觀

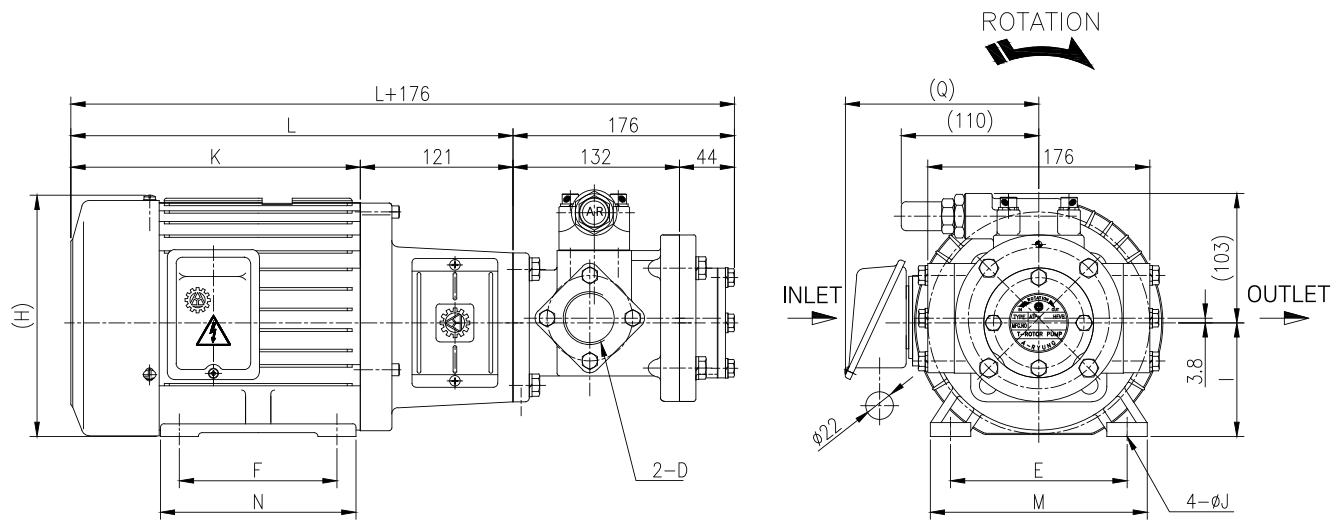

Output	Poles	E	F	H	I	J	K	L	M	N	Q
1500W	4	140	125	193	90	10	230	354	172	155	154
1500W	6	190	140	232	112	12	256	377	230	170	171
2200W	4	190	140	232	112	12	256	377	230	170	171
2200W	6	190	140	232	112	12	256	377	230	170	171

Type	D (Port Dia)	
	INLET	OUTLET
AMTP-320HFVB	PT 1"	PT 1"
AMTP-340HFVB	PT 1 1/4"	PT 1"

Application 適用	Material 材質	
<ul style="list-style-type: none"> Fluid: Oils Kinematic viscosity (at 40°C): 20 ~ 220 cSt Use temperature <ul style="list-style-type: none"> - NBR: 80°C below - FKM: 180°C below 	<ul style="list-style-type: none"> Motor Flame : Aluminum Pump body : Cast iron Port housing : Cast iron Pump cover : Cast iron Bearing : #6305zz, #63/22zz 	<ul style="list-style-type: none"> Shaft : Steel Rotor : Powder steel Oil-seal : NBR, FKM(Optional) <ul style="list-style-type: none"> - Ø25×Ø40×7t



AFC - 200 - 12MSFVB - T10

① ② ③ ④

- ① ARYUNG Fan cooler unit
- ② Motor output / モーター出力
- ③ Pump classification / ポンプ分類
- ④ Tank capacity / タンク容量

- Excellent heat exchange efficiency by applying a fan cooler and a small circulation pump as an air-cooled type.
- Easy to use and compact in appearance, it is suitable for machine tools and various industrial machines.

- 空冷式としてファンクーラーと小型循環ポンプを採用し、熱交換効率に優れています。
- 使いやすくコンパクトな外観で、工作機械や各種産業機械に適しています。

Pump Spec'

Type	1500 rpm (50Hz, 4p)			1800 rpm (60Hz, 4p)			INLET	OUTLET
	Discharge Volume (ℓ/min)	Max' Pressure (MPa)		Discharge Volume (ℓ/min)	Max' Pressure (MPa)			
		100W	200W		100W	200W		
12MSFVB	3.7	0.5	0.5	4.5	0.5	0.5	PT 1/4"	PT 1/4"
13MSFVB	6.7	-	0.5	8.1	-	0.5	PT 3/8"	PT 3/8"

Motor Spec'

Motor Output (W)	Frequency (Hz)	Voltage (V)	Current (A)	Motor speed (rpm)	Phase (Ø)	Poles (P)
100W	50/60	200	0.65	1430	3	4
	60	220	0.6	1720		
200W	50/60	200	1.3	1430	3	4
	60	220	1.1	1710		

■ Protection class / 保護等級 : IP44

■ Insulation class / 絶縁階級 : B

Type	Tank Capacity (ℓ)	Fan Motor				
		Motor Output	Phase	Frequency	Voltage	Current
AFC-100-12MSFVB-T10	10	48W	1 Ø	50/60 Hz	220~240V	0.22 A
AFC-200-13MSFVB-T14	14					

※ TANK capacity and mounting location can be manufactured upon request of the orderer.

※ タンク容量と取り付け位置は、ご注文者の要求に応じて製造できます。

Appearance | 外觀

AFC-100-12MSFVB-T10

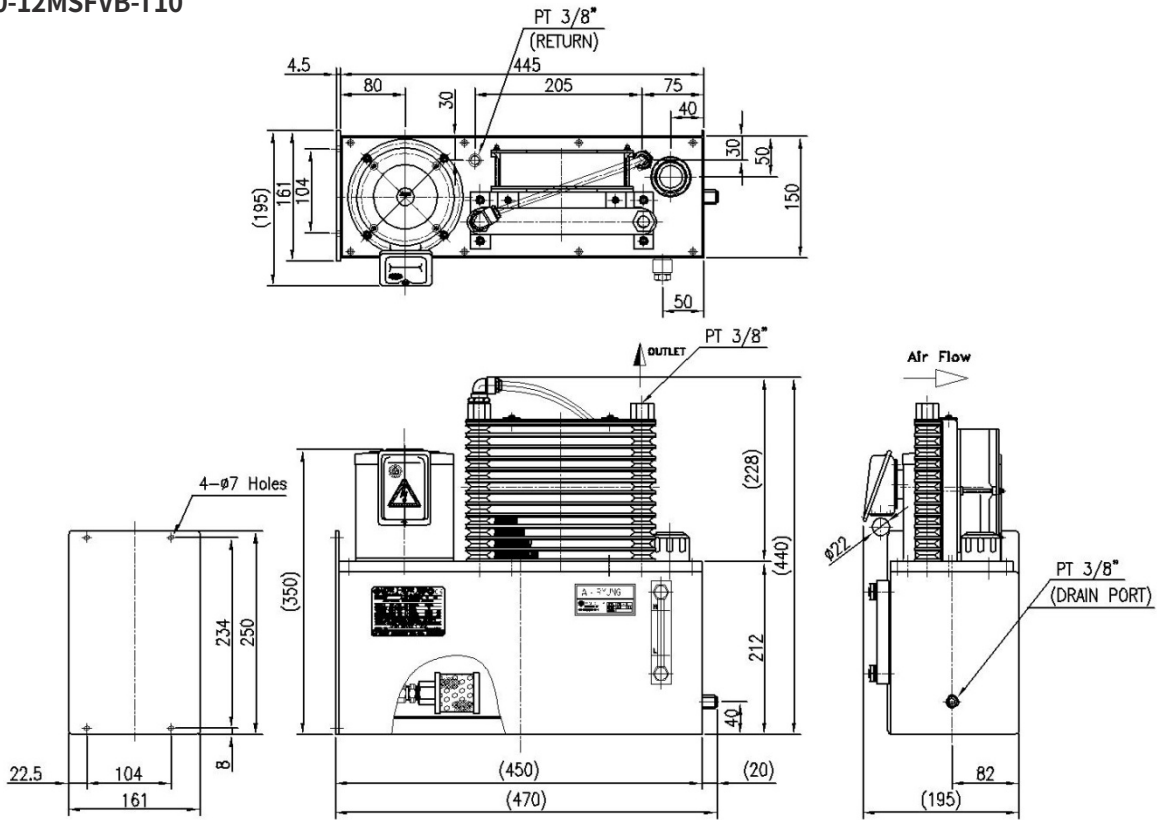

AFC-200-13MSFVB-T14

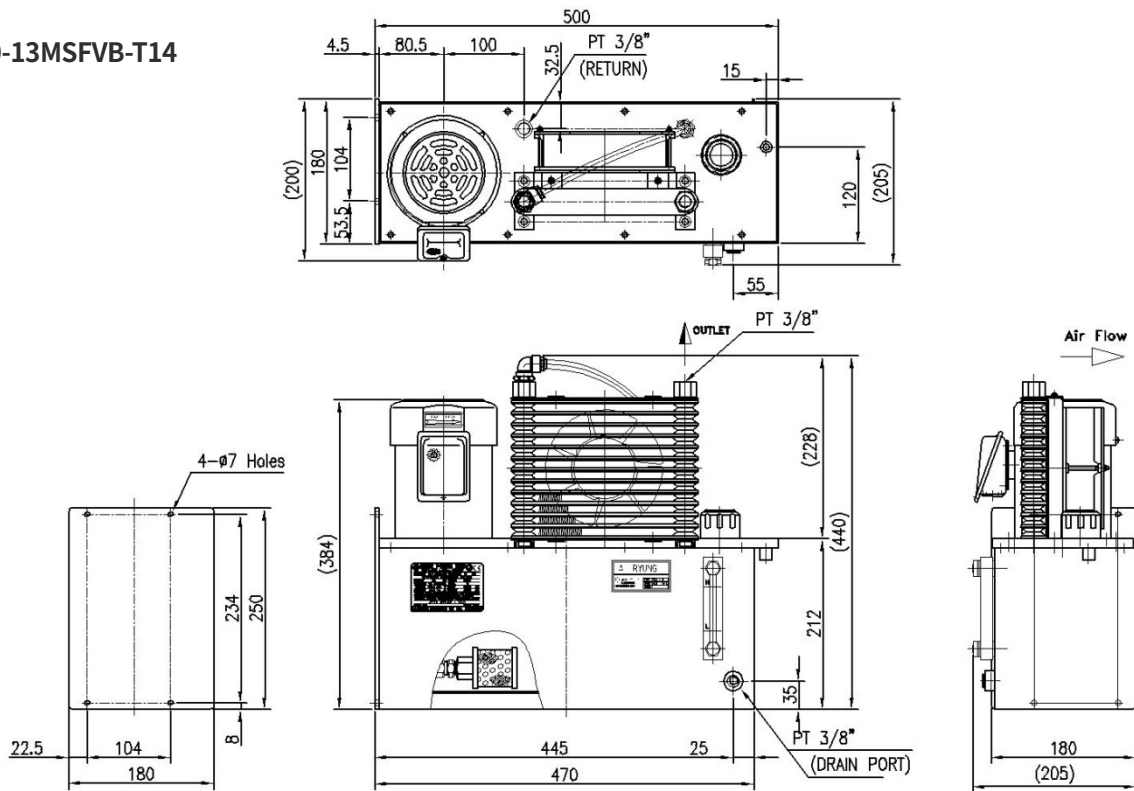

Appearance | 外觀

MODEL : AFC-010LT

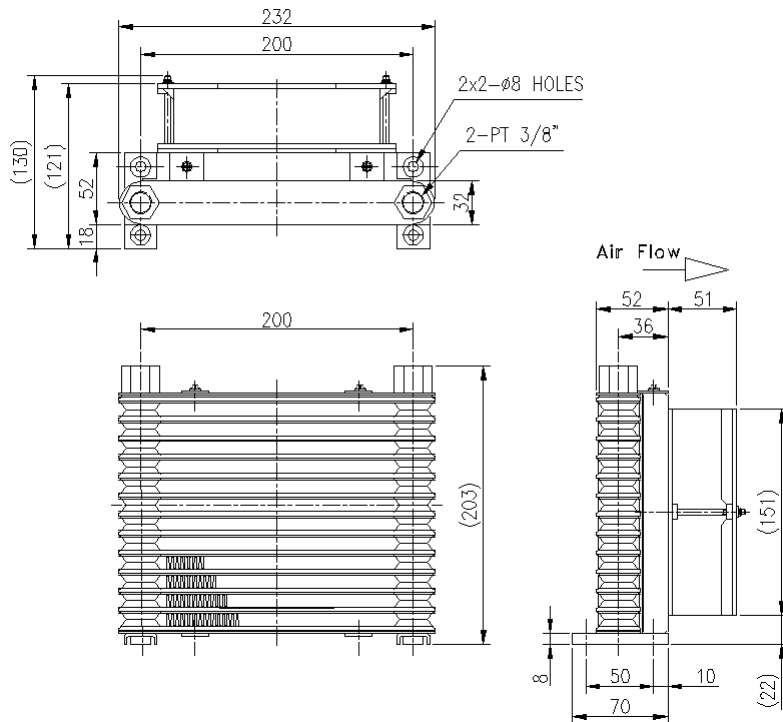

Motor Output	48W
Voltage	AC 220V
Current	0.22A
Dis' Volume	10 ℓ/min
Max' Pressure	15 bar

MODEL : AFC-100LT

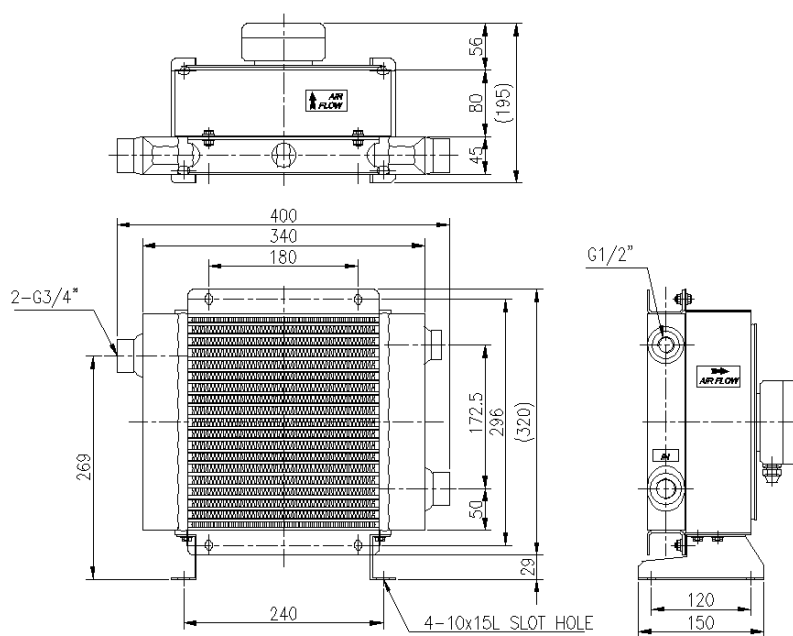

Motor Output	104W
Voltage	AC 220V
Current	0.48A
Dis' Volume	100 ℓ/min
Max' Pressure	35 bar

05 Failure cause and countermeasure | 故障原因と対策

Breakdown details	Phenomenon or possible cause	Check item • Method	Treatment • Countermeasures		
Lack of discharge Bad suction Pressure does not rise	There is little flow out. No fluid comes out.	Measure the suction pressure with a vacuum gauge -0.03MPa or more if displayed, cavitation.	Lower the viscosity of used oil.		
		Blockage of suction pipe. Check the contamination of the suction filter.	Suction filter cleaning.		
		Lack of flow in the tank. Check by oil gauge or visually.	Replenish oil to the specified amount. Criteria: 3~4 times the amount of discharge per minute is required.		
		Is there any possibility of air ingress through the pipe connection?	Tighten the piping		
		Is the viscosity of the oil low compared to the operating pressure?	Use of oil of suitable viscosity for the pump.		
		While looking at the pressure gauge, tighten the pressure adjustment bolt of the relief valve. Result: The pressure does not rise.	The relief valve is expected to get stuck, so clean the relief valve to remove the foreign material.		
		While looking at the pressure gauge, tighten the pressure adjustment bolt of the relief valve. Result: pressure rises.	Since the relief valve is operating normally, increase the set pressure.		
		Check the rotation direction with the opposite eye of the pump rotation direction.	Correction to the direction of rotation indicated on the pump.		
		Are the flow paths on the suction side and discharge side blocked?	The suction side and discharge side flow paths are opened. The suction side and discharge side flow paths are expanded.		
Oil leakage	Oil leakage occurs in the oil seal.	Is the rotation direction of the pump wrong?	Pump repair or replacement.		
		Is there pressure in the suction pipe?	The pump is higher than the oil level and installed within 1m. The internal pressure of the oil seal is Max' 0.03MPa.		
		The oil temperature is higher than the durability temperature of the oil seal.	Use of special material oil seal (contact us)		
		The type of oil is not suitable for the oil seal.	Oil seal change and pump replacement.		
Oil does not come out. The breaker works.	The motor does not rotate.	Power failure or voltage drop.	Check the power equipment.		
		Are the magnetic switch or circuit breaker working?	Reset the magnetic switch and circuit breaker.		
		Power cord disconnection or poor connection.	Replace or reconnect power cord.		
	Overload	Is the required power adequate?	Increase the motor power or reduce the size of the pump. If you do not know the cause, please contact Ayung Machinery after checking the oil viscosity, working pressure, and piping conditions.		
		Even if the pump is turned by hand, it does not rotate. Rotation is heavy	Is the viscosity or lubricity of the fluid used?	Repair because there is a possibility that the rotor is worn or foreign substances are stuck.	
		Is the fluid used to be dirty?	Replace or repair the pump.		
The sound is loud. Abnormal noise generation	The suction resistance is large. (Cavitation) The suction pipe is too thin. The suction pipe is too long. Pump rotation is too fast. The suction filter is becoming resistance. The viscosity of the oil is too high. The suction height is too high.	Suction pressure is measured with a vacuum gauge. If it is displayed above -0.03 MPa, cavitation.	Suction pressure within -0.03 MPa. (Direction close to atmospheric pressure) Make the pipe thicker. Shorten the piping. Slow pump rotation. Replace the filter with a low resistance. It lowers the viscosity of the oil. Lower the suction height.		
			Are inhaling air together (Aeration)	Are there any air bubbles in the tank? Is the piping loose?	No air intrusion into tanks, piping or pumps.
			Poor concentricity of the coupling.	Check that the return piping is in the oil.	Return piping is immersed in oil.
		Check whether the concentricity of both couplings is abnormal.	Correct within the standard value of the coupling..		

故障内容	現象または推定原因	チェック項目・方法	処理・対策
吐出量不足 吸引不良 圧力が上がらない。	出てくる流量が少ない。 流体が出てこない。	真空計で吸引圧力を測定 -0.03MPa以上を表示すると、キャビテーション	使用注意点を下げる
		吸入配管の詰まり。 サクシオンフィルタの汚れの状態をチェック。	サクシオンフィルタの掃除
		タンクの流量不足。 油面計または肉眼で確認した。	オイルを規定量まで補充 基準: 毎分吐出の3~4倍に相当する量が必要
		配管接続部に空気混入の可能性はないのか?	配管をしっかり締める。
		使用圧力に比べて油の粘度がナトナ?	ポンプに適した粘度のオイルを使用。
		圧力計を見ながらリリーフ弁の圧力調整ボルトを 締めてみる。 結果: 圧力が上がらない。	リリーフ弁に異物が詰まりが予想されるので、 リリーフバルブを洗浄して異物除去
		圧力計を見ながらリリーフ弁の圧力調整ボルトを 締めてみる。 結果: 圧力が上昇する。	リリーフ弁が正常に動作しているので、設定圧力を 増加させる。
		ポンプの回転方向反対した。 肉眼で回転方向を確認。	ポンプに表示された回転方向に修正。
		吸込側と吐出側の流路が遮断されていないか?	吸込側と吐出側流路を開放。 吸込側と吐出側流路を拡張します。
OIL漏れ	Oil-sealから漏れ発生。	ポンプの回転方向が間違っていないか?	ポンプの修理または交換します。
		吸入配管に圧力がかかっていないか?	ポンプは、油面よりも高くして、1m以内に設置 オイルシールの耐圧はMax10.03MPa
		油温がオイルシールの耐久性温度よりも高い	特殊な材料のオイルシールの使用(当社お問い合わせ)
		オイルの種類がオイルシールに不適合	オイルシールの交換とポンプ交換。
Oilが出ない。 Oilが出ない。 ブレーカ動作します。	Motorが回転しない。	停電や電圧低下	電源設備をチェック。
		電磁開閉器、遮断器動作していないか?	電磁開閉器、遮断器をリセット。
		電源コードの断線や接続不良	電源コードを交換または再接続。
	過負荷	所要動力はジョクジョンハンガ?	モータ出力を上げたり、ポンプのサイズを下げる。 原因がわからない場合は、オイルの粘度、使用圧力、配管の状態を確認した後、弊社までご連絡ください。
	ポンプを手で回しても回転しない。 回転が重い。	使用流体の粘度や潤滑性はジョクジョンハンガ? 使用流体が汚れたではないか?	Rotorが磨耗しているか、異物が挟まっている可能性があるので、修理する。 ポンプ交換または修理する。
音が大きい。 奇妙な騒音発生。	吸入抵抗が大きい。 吸引配管がとても細い。 吸引配管が長すぎる。 ポンプの回転がとても速い。 吸入フィルタが抵抗となっている。 オイルの粘度が高すぎる。 吸引の高さが高すぎる。	真空計で吸引圧力を測定 -0.03MPa以上を表示すると、キャビテーション	吸込圧力-0.03MPa以内(大気圧に近い方向) 配管を太くする。 配管を短くする。 ポンプの回転を遅くする。 フィルタの抵抗が少ないものに交換する。 オイルの粘度を低くする。 吸引の高さを下げる。
		タンク内に気泡がいませんか? 配管が緩んいませんか?	タンク、配管、ポンプ内に空気の侵入がないように調整します。
		リターン配管がオイルの中に入っていることを確認	戻り配管はオイルの中に浸す。
	カップリングの同心不良	両カップリングの同心度が異常ないことを確認	カップリングの規格値以内修正する。

Single Voltage | 単一電圧

Right Direction

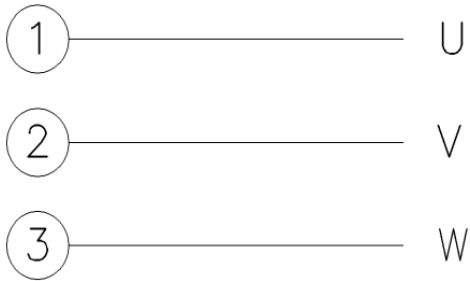

Reverse Direction

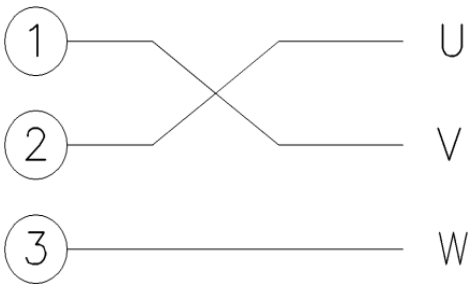

Double Voltage | 倍電圧

Low Voltage (200V, 220V)

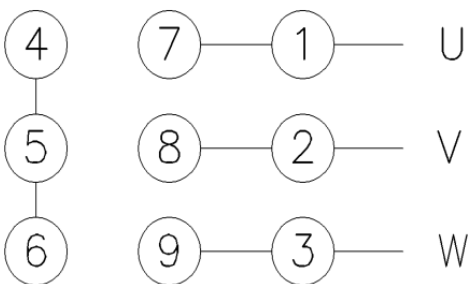

High Voltage (440V)

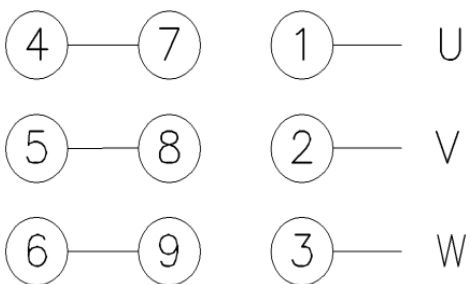

Dual Voltage | デュアル電圧

Low Voltage (200V, 220V)

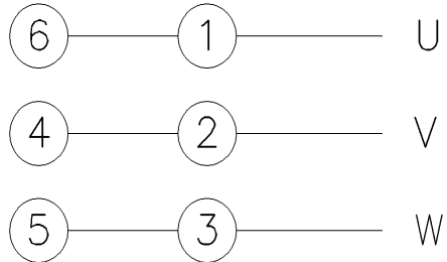

High Voltage (380V)

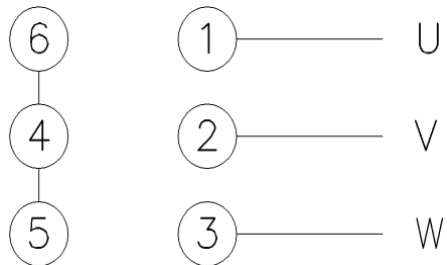

Free Voltage | 自由電圧

Low Voltage (200V~240V)

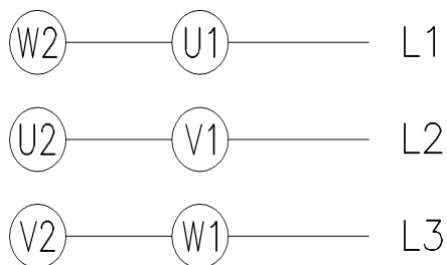

High Voltage (380V~440V)

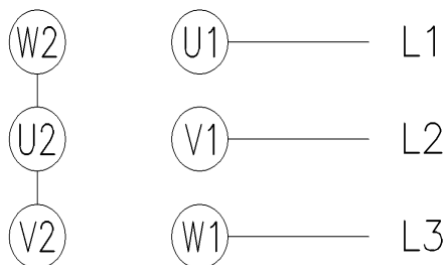

From Korea's leading brand to a global brand!! Aryung is always with you in the development of machine tools!!!

韓国を代表するブランドからグローバルブランドへ!! Aryungは常に工作機械の開発に携わっています!!!



Bronze Tower Order of Industrial Service Merit
ブロンズタワー産業勲章



System assembly line
システム組立ライン



World Machine Tool Exhibition
世界工作機械展



Automated processing line
自動処理ライン

	Established Ayung Machine Tools	1976.05	アユン工作機械を設立
Designated as a specialized oil pump company by the Ministry of Commerce and Industry (No.79-118)		1980.04	商工省指定オイルポンプ専門会社 (No.79-118)
Designated as a company approved for modernization action plan (Small and Medium Business Corporation No.81-208)		1982.02	近代化行動計画 (中小企業法人No.81-208) の承認を受けた会社に指定
Awarded the Presidential Citation for Excellent Small and Medium Business (No. 54709)		1982.05	優秀な中小企業で大統領賞を受賞 (No. 54709)
Awarded the Deputy Prime Minister's Award, selected as an excellent domestic machinery development company (No.87-104)		1987.09	国内の優秀な機械開発会社選ばれ、副首相賞を受賞 (No.87-104)
Self-cleaning service plaque (National Tax Service)		1992.12	セルフクリーニングサービスプラーク (国税庁)
Overseas Market Export Industry Award (Korea International Trade Promotion Corporation)		1993.05	海外市場輸出産業賞 (韓国国際貿易振興公社)
"CE" European safety standard certification (TÜV Rheinland)		1996.11	「CE」欧州安全基準認証 (TÜV Rheinland)
"EM" machinery, parts and materials excellent quality standard certification (Korea Institute of Technology and Standards)		1999.06	「EM」機械、部品、材料の優れた品質基準認証 (韓国科学技術研究院)
ISO 9001 quality management system certification (KSA)		1999.11	ISO 9001品質管理システム認証 (KSA)
"CSA-C-US" American and Canadian safety standards certification (CSA INTERNATIONAL)		2000.10	「CSA-C-US」アメリカおよびカナダの安全基準認証
		2000.11	(CSAインターナショナル)
Awarded by the Minister of Commerce, Industry and Energy for export contribution (No.47955)		2003.11	輸出貢献に対して商工エネルギー大臣から授与 (No.47955)
Awarded the Minister of Commerce, Industry and Energy citation for trade promotion economic development (No.54163)		2003.12	貿易振興経済発展のため商工エネルギー大臣賞を受賞 (No.54163)
Commendation from Jeollanam-do governor for export contribution (No.1421)		2004.11	全羅南道知事からの輸出貢献表彰 (No.1421)
Established a local subsidiary in China "Along Machine Tools (Dalian) Co., Ltd."		2005.12	中国に「工作機械 (大連) 株式会社」の現地子会社を設立。
Awarded the Prime Minister's Award for "Machine Tool Development" (No.133740)		2006.12	「工作機械開発」で首相賞を受賞 (No.133740)
Awarded the 1 Million Dollar Export Tower to commemorate the Trade Day		2007.04	貿易の日を記念して100万ドルの輸出タワーを受賞
Established company-affiliated research institute (Korea Industrial Technology Association)		2007.09	会社付属の研究を設立 (韓国産業技術振興協会)
"MAIN-BIZ" (management innovation small and medium business) certification (Small and Medium Business Administration)		2007.10	「MAIN-BIZ」(経営革新中小企業) 認証 (中小企業庁)
Acquired single PPM certification		2007.10	シングルPPM認証を取得
"INNO-BIZ" (Technology Innovative Small and Medium Business) Certification "AA Grade" (Small and Medium Business Administration)		2008.05	「INNO-BIZ」(技術革新中小企業) 認証「AAグレード」(中小企業庁)
Received the Bronze Tower Order of Industrial Service Merit (Contribution to National Industrial Development)		2009.02	ブロンズタワー産業勲章 (国家産業開発への貢献) を受賞
Acquired "NRTL" North American stability certification		2009.03	米国安定認証「NRTL」を取得
Received a commendation from the head of the National Tax Service (No.47687)		2010.11	国税庁長官から表彰を受けた (No.47687)
Acquired the certification of the minimum efficiency system for motors of 0.75kW or more (Korea Energy Agency)		2012.02	0.75kW以上のモーターの最低効率システムの認証を取得 (韓国エネルギー公団)
Jeollanam-do Export Prize (No. 39)		2014.02	全羅南道輸出賞 (第39号)
Acquired premium efficiency standard (IE3) certification (Korea Energy Agency)		2014.10	プレミアム効率基準 (IE3) 認証を取得 (韓国エネルギー公団)
Awarded the prestigious longevity company award (Ministry of Trade, Industry and Energy)		2015.03	名誉ある長寿企業賞を受賞 (産業通商資源部)
Deputy Prime Minister of Model Taxpayer and Minister of Strategy and Finance Award (National Tax Service)		2015.12	模範納税者に副首相兼企画財務大臣賞 (国税庁)
Awarded the 3 Million Dollar Export Tower to commemorate the Trade Day		2016.12	貿易の日を記念して300万ドルの輸出タワーを受賞
Awarded the 5 Million Dollar Export Tower to commemorate the Trade Day		2018.07	貿易の日を記念して500万ドルの輸出タワーを受賞
Selected as a Global small giant company (Ministry of SMEs & Startups.)		2019.04	グローバルな強小企業に選定 (中小ベンチャー企業部)
Selected as a Materials & Parts specialized company (Ministry of trade, industry & energy)		2019.10	素材・部品 専門企業に選定 (産業通商資源部)
Received the Presidential Citation for National Industrial Development (No.220639)		2020.03	国家産業の発展大統領表彰を受賞 (No.220639)



ARYUNG MACHINERY IND. CO., LTD



KOREA HeadQuarters

#48, Damsun-ro, Keumseong-myun,
Damyang-gun, Jeonnam, Korea

全南 潭陽郡 金星面 潭淳路 48
TEL : +82-61-380-2200 | FAX : +82-61-382-3094
URL : <http://www.aryung.co.kr> | Email : aryung@aryung.co.kr



CHINA Subsidiary Company

#9 Tieshan East 3 Road Central Industrial District
Economic Development Zone Dalian City China

TEL : +86-411-8734-6601~4 | FAX : +86-411-8734-6605
URL : <http://www.a-ryung.com.cn> | Email : a-ryung@163.com

In addition to improving the quality of the product are subject to change without notice in selecting products please contact our technical team.
製品の品質向上に加えて、製品の選択において予告なしに変更される場合があります。当社の技術チームにお問い合わせください。